



# **LONDON BUS SERVICES LIMITED**

---

Specification for New Buses

Version 2.5

Issued April 2024

Effective from Tranche 913



## Preface

This specification will determine the technical characteristics required for all new London buses.

Where an Original Equipment Manufacturer (OEM) perceives that a particular feature of this document should be changed, this should be raised by the OEM with the Approval Authority (London Bus Service Limited - LBSL) assessor present at the assessment, or in writing to the Approval Authority (LBSL) Nominated Officer in the absence of an assessor. The competent authority (LBSL) will assess the proposal based on their judgment and provide instruction to the assessment facility.

OEMs are directly or indirectly barred from interfering with any assessment undertaken as part of this specification and prohibited from altering any characteristics that may impact the assessment, including but not restricted to vehicle setting, laboratory environment etc.

| <b>Version</b> | <b>Publisher</b> | <b>Date</b> | <b>Details</b>         |
|----------------|------------------|-------------|------------------------|
| 2.5            | TfL              | April 2024  | LBSL Bus Specification |

## Disclaimer

LBSL has taken all appropriate caution to guarantee that the information contained in this protocol is correct and demonstrates the prevailing technical decisions taken by the organisation. In the occasion that a mistake or inaccuracy is identified, LBSL retains the right to make amendments and decide on the assessment and future outcome of the affected requirement(s).

©Copyright LBSL 2024: This work is the intellectual property of LBSL with some sections replicated with the permission of Euro NCAP. A licence is permitted for this material to be distributed for non-commercial and educational use on condition that this copyright statement shows on the replicated materials and information is provided that the copying is by permission of LBSL. To circulate otherwise or to republish will be deemed a breach of intellectual property rights.



## Version Control

| Revision Date | Tranche Implementation Date | Revision No | Page No | Section   | Summary of changes   |
|---------------|-----------------------------|-------------|---------|---|--|
| Dec 18        | 670                         | 1.0         |         |   | Issued   |
| May 19        | 670                         | 1.1         | 8       | 3 Regulatory Compliance                             | Clarifications of certification, text added regarding types and variants.  |
|               |                             |             | 24      | 4.3.3 Intelligent Speed Assistance (ISA)            | Clarification of map updating, definition of warning Human Machine Interface (HMI) and symbol.                               |
|               |                             |             | 30      | 4.3.4.2 Camera Monitor System (CMS): Reversing      | Clarification of certification and about Reg 46.   |
|               |                             |             | 34      | 4.3.5.2 Accelerator Light                           | Clarification of activation levels, and auditory warning.  |
|               |                             |             | 37      | 4.3.5.3 Brake toggle system                         | Clarification of certification, and failure warning.   |
|               |                             |             | 38      | 4.3.5.4 Pedal acoustic feedback system              | Description of goals added.  |
|               |                             |             | 39      | 4.3.6 Runaway Bus Prevention                        | Driver input and maintenance requirements clarified.   |
|               |                             |             | 43      | 4.3.7 Halt Brake                                    | Moved to separate section, maintenance checks added.   |
|               |                             |             | 45      | 4.4.1 Acoustic Conspicuity                          | Requirements on hybrid vehicle added, notes about developments, diagrams showing speaker location, and update details added. |
|               |                             |             | 51      | 4.5.6 Flooring and Slip prevention                  | Requirements for new materials added.  |
|               |                             |             | 59      | 4.6.4 VRU Frontal Crashworthiness: Wiper Protection | Wipers defined in relation to bus dimensions.  |
|               |                             |             | 63      | 6.1 Vehicle capacity                                | Clarification of non-conforming vehicle dimensions, and wipers in relation to dimensions.                                    |
|               |                             |             | 78      | 8.3 Heating, Ventilation & Air Conditioning (HVAC)  | Clarifications made.   |



|        |     |     |          |   |  |
|--------|-----|-----|----------|---|--|
|        |     |     |          | All attachments relevant to above                       | Updated to reflect changes to the spec.  |
| Jul 20 | 734 | 2.0 | 2        | 1.4 Terminology   | Structure updated; text added to clarify document scope.   |
|        |     |     | 4 to 7   | 2 Status of Application Requirements                    | Corrections made to subsection descriptors and timings.  |
|        |     |     | 13       | Section 4.2.1 Protecting the driver from Assault        | Driver Assault screen specification updated to included pathogen protection  |
|        |     |     | 13       | 4.3.1 Acceleration performance                          | Lower maximum acceleration limit removed.  |
|        |     |     | 14 to 18 | 4.3.3 Intelligent Speed Assistance (ISA)                | Text added to operating modes and performance requirements (Restricted Operating Mode (ROM), Option types, ROM activation time, Speed Limit indicator requirements). |
|        |     |     | 21 to 23 | 4.3.4.4 Camera Monitor System (CMS): Mirror Replacement | Text added – HMI performance requirements defined.   |
|        |     |     | 24       | 4.3.5 Pedal Application error                           | Text added – Guidance as to current status of safety feature.  |
|        |     |     | 25 to 28 | 4.3.5.2 Accelerator Light System (ALS)                  | Accelerator Light symbol and HMI requirements defined.   |
|        |     |     | 29       | 4.3.5.3 Brake Toggle System                             | Text added to clarify performance requirements and further work.   |
|        |     |     | 31       | 4.3.7 Halt Brake  | Text added to better define performance requirements.  |
|        |     |     | 31 to 34 | 4.4.1 Acoustic Conspicuity                              | Text added to better define performance requirements.  |
|        |     |     | 37 to 38 | 4.5.6 Flooring and Slip Prevention                      | Text added to better define performance and certification requirements.  |
|        |     |     | 42       | 4.5.7 Door Safety                                       | Door/ramp interlock safety logic requirement added   |
|        |     |     | 40 to 41 | 4.6.1 VRU Frontal Crashworthiness: Minimum Geometry     | Corrections and clarifications made to performance and assessment requirements.  |
|        |     |     | 41 to 42 | 4.6.2 VRU Frontal Crashworthiness: Enhanced Geometry    | Updates made to performance and assessment requirements.   |



|  |  |  |    |  |  |
|--|--|--|----|--|--|
|  |  |  | 42 | 4.6.3 VRU Frontal<br>Crashworthiness: Energy<br>Absorption | Minimum HIC <sub>15</sub> value updated to 1350  |
|  |  |  | 53 | 6.2 Energy Efficiency - Electric<br>Vehicles               | Charger connection type standard updated   |
|  |  |  | 58 | 8.3 Heating, Ventilation & Air<br>Conditioning (HVAC)      | Updated to separate driver cab Air-conditioning system from rest of<br>vehicle. Evidence required in line with Attachment 9. |
|  |  |  | 63 | 10.3 Other internal and external<br>signs and notices      | Updated to link to latest version of the London Buses- Bus<br>Graphics Standard  |
|  |  |  |    | Attachment 7: Wheelchair Floor<br>Logo                     | Logo position and dimension tolerances updated.  |
|  |  |  |    | Attachment 8: Handrail<br>requirements                     | Positional dimension tolerance updated.  |
|  |  |  |    | Attachment 9: HVAC<br>Assessment Protocol                  | Test procedure updated. Pre-test design evidence requirement<br>added.   |
|  |  |  |    | Attachment 17: ISA Assessment<br>Protocol                  | Test requirements and procedures updated in line with<br>specification updates.  |
|  |  |  |    | Attachment 18: ISA Guidance<br>Notes                       | Aftermarket equipment requirements updated.  |
|  |  |  |    | Attachment 19: Bus Vision<br>Standard Assessment Protocol  | Ocular assessment point changed from Ambinocular to monocular.<br>Assessment protocol requirements updated.                  |
|  |  |  |    | Attachment 20: Bus Vision<br>Standard Guidance notes       | Language and consistency updates.  |
|  |  |  |    | Attachment 21: Blind spot Mirror<br>Guidance Notes         | Language and consistency updates.  |
|  |  |  |    | Attachment 22: CMS Mirror<br>replacement Guidance Notes    | Language and consistency updates.  |
|  |  |  |    | Attachment 23: Rear-view CMS<br>Guidance Notes             | Language and consistency updates.  |



|  |  |  |  |  |   |
|--|--|--|--|--|---|
|  |  |  |  | Attachment 24: Blind Spot Warning Assessment Protocol          | Test scenarios and procedures updated.                                    |
|  |  |  |  | Attachment 26: Pedal Application Error Assessment Protocol     | Test procedures updated in line with specification updates.               |
|  |  |  |  | Attachment 28: Runaway Bus Assessment Protocol                 | Test scenarios and procedures updated.                                    |
|  |  |  |  | Attachment 29: Runaway Bus Guidance Notes                      | Language and consistency updates.   |
|  |  |  |  | Attachment 30: Acoustic Conspicuity Assessment Protocol        | Test procedures updated in line with specification updates.               |
|  |  |  |  | Attachment 31: Acoustic Conspicuity Guidance Notes             | Language and consistency updates.   |
|  |  |  |  | Attachment 32: Slip Protection Assessment Protocol             | Test scenarios and procedures updated in line with specification updates. |
|  |  |  |  | Attachment 33: Slip Protection Guidance Notes                  | Test scenarios and procedures updated in line with specification updates. |
|  |  |  |  | Attachment 34: Occupant Friendly Interiors Assessment Protocol | Test zone updated.  |
|  |  |  |  | Attachment 36: Bus Impact Test Standard Assessment Protocol    | Minimum HIC <sub>15</sub> value updated to 1350                           |
|  |  |  |  | Attachment 38: VCW – Minimum Geometry Guidance Notes           | Test areas and procedures updated in line with specification updates.     |
|  |  |  |  | Attachment 39: VCW – Enhanced Geometry Assessment Protocol     | Test areas and procedures updated in line with specification updates.     |



|          |  |     |          |   |  |
|----------|--|-----|----------|---|--|
|          |  |     |          | Attachment 40: VCW – Enhanced Geometry Guidance Notes                       | Test areas and procedures updated in line with specification updates.  |
|          |  |     |          | Attachment 41: Wiper Protection Guidance Notes                              | Attachment number updated.   |
| Dec 2020 |  | 2.1 | 1        | 1.1 Scope   | Removal of reference to Class II vehicles – All relevant Attachments updated to reflect this                     |
|          |  |     | 3 to 6   | 2 Status of application of requirements                                     | Table updated to reflect changes in research work packages (Pedal Confusion)                                     |
|          |  |     | 8        | 3.1 Regulatory Compliance   | Clarification as to cost responsibility for parties  |
|          |  |     | 20       | 4.3.4.3 Direct Vision Score (DVS) and Enhanced total Bus Vision Score (BVS) | Vision Score requirements updated to reflect changes to assessment protocol (see Attachment 19 for full details) |
|          |  |     | 30 to 34 | 4.4.1 Acoustic Conspicuity  | Correction to maximum applicable speed (pg 32), updates to requirements  |
|          |  |     | 42       | 4.6.4 VRU Frontal Crashworthiness: Wiper Protection                         | Update to required HIC <sub>15</sub> requirements for new and existing bus models                                |
|          |  |     | 46       | 6.1 Vehicle Capacity  | Table 6.1 updated to reflect changes to entrance and exit door width requirements                                |
|          |  |     | 47       | 6.3 Minimising Dwell time   | Entrance and exit door width requirements updated  |
|          |  |     |          | Attachment 1: London Bus Cycle  | Clarification to Reg. 101 applicability  |
|          |  |     |          | Attachment 3: Fleet Management Systems (FMS)                                | Updated with current FMS requirements  |
|          |  |     |          | Attachment 11: CCTV   | Updated with current CCTV requirements   |
|          |  |     |          | Attachment 12: Exterior and Interior Notices                                | Updated to link in with relevant BVS section within this document (section 10)                                   |
|          |  |     |          | Attachment 14: Free Issued Equipment  | Updated with current Free Issued Equipment requirements  |



|          |     |     |          |   |  |
|----------|-----|-----|----------|---|--|
|          |     |     |          | Attachment 17: Intelligent Speed Assistance (ISA) Assessment Protocol | Updated to test requirement – 9.1.3.6.b  |
|          |     |     |          | Attachment 18: Intelligent Speed Assistance (ISA) Guidance Notes      | ISA strategy requirements updated in line with those of BVS requirements (Section 4.3.3) and Attachment 17 |
|          |     |     |          | Attachment 26: Pedal Application Error Assessment Protocol            | Test trac requiremetns updated, Appendix A updated to take Test Track gradient into account                |
|          |     |     |          | Attachment 30: Acoustic Conspicuity Assessment Protocol               | Updated in line with changes made to Section 4.4.1 of BVS  |
|          |     |     |          | Attachment 31: Acoustic Conspicuity Guidance Notes                    | Updated in line with changes made to Section 4.4.1 of BVS and Attachment 30                                |
|          |     |     |          | Attachment 41: Bus Front End Design – Wiper Protection Guidance Notes | Updated to reflect changes made to BVS section 4.6.4   |
| Apr 2022 | 830 | 2.2 | 7        | 3.1 Regulatory and TfL Compliance                                     | Amendment of R118 to Rev 03, inclusion of PSVAR2000 compliance requirements                                |
|          |     |     | 8 to 9   | 3.2 Test Process  | Addition of Matrix of certification requirements   |
|          |     |     | 18       | 4.3.3.3 Intelligent Speed Assistance                                  | Amendment to speed limit display wording   |
|          |     |     | 20       | 4.3.4.2 Camera Monitor System (CMS): Reversing                        | Amendment to mirror class definition   |
|          |     |     | 31 to 35 | 4.4.1 Acoustic Conspicuity  | Amended to include requirement of Responsive AVAS  |
|          |     |     |          | 4.5.7(pg 38), 4.7(pg 43), 6.1(pg 46), 7(pg 53 & 54) and 8.4 (pg 63)   | Amendment for General Assembly Drawing submission and approval process                                     |
|          |     |     | 40       | 4.6.1 VRU Frontal Crashworthiness: Minimum Geometry                   | Correction to figure numberings  |





|  |  |  |          |   |   |
|--|--|--|----------|---|---|
|  |  |  | 58 to 62 | 8.3 Heating, Ventilation & Air Conditioning (HVAC)                    | Updated specification                                       |
|  |  |  |          | Attachment 5: Driver-Passenger 2 Way Intercom Systems                 | Updated Attachment  |
|  |  |  |          | Attachment 6: Standard for the Fire Retardant Properties of Materials | Amended to reflect requirement of Reg. 118 Rev 03 adherence |
|  |  |  |          | Attachment 9: Heating Ventilation and Air Conditioning (HVAC)         | Amended to reflect changes in BVS document (section 8.3)    |
|  |  |  |          | Attachment 11: CCTV   | Updated current CCTV requirements                           |
|  |  |  |          | Attachment 17: Intelligent Speed Assistance (ISA) Assessment Protocol | Amendment to weather condition requirements                 |
|  |  |  |          | Attachment 19: Bus Vision Standard Assessment Protocol                | Correction to referenced BVS section number                 |
|  |  |  |          | Attachment 24: Blind Spot Warning (BSW) Assessment Protocol           | Correction to referenced BVS section number                 |
|  |  |  |          | Attachment 26: Pedal Application Error Assessment Protocol            | Correction to referenced BVS section number                 |
|  |  |  |          | Attachment 27: Pedal Application Error Guidance Notes                 | Amendment to Brake Toggling Task orders                     |
|  |  |  |          | Attachment 28: Runaway Bus Prevention Assessment Protocol             | Correction to referenced BVS section number                 |
|  |  |  |          | Attachment 30: Acoustic Conspicuity Assessment Protocol               | Amended to reflect changes in BVS document (section 4.4.1)  |



|          |     |     |          |   |   |
|----------|-----|-----|----------|---|---|
|          |     |     |          | Attachment 34: Occupant Friendly Interiors Assessment Protocol        | Correction to referenced BVS section number                                 |
|          |     |     |          | Attachment 41: Bus Front End Design – Wiper Protection Guidance Notes | Correction to referenced BVS section number                                 |
| Aug 2022 | 872 | 2.3 | 6        | 2 Status of Application of Requirements                               | Table 2_1 updated to reflect upcoming safety features                       |
|          |     |     | 9 to 10  | 3.2 Test Process  | Matrix of certification updated and amended                                 |
|          |     |     | 10       | 3.3.1 Type-, variant- and version designations                        | Table 2_2 updated to reflect upcoming safety features                       |
|          |     |     | 14 to 18 | 4.3.2 Advanced Emergency Braking (AEB)                                | Addition of subsections, amendments to True and False Positive requirements |
|          |     |     | 24       | 4.3.4.2 Camera Monitor System (CMS): Reversing                        | Amendment of applicable UNECE Regulation to 158                             |
|          |     |     | 35       | 4.3.8 Tyre Pressure Monitoring Systems (TPMS)                         | New section added, Tyre Pressure Monitoring Systems                         |
|          |     |     | 36       | 4.3.9 Alcohol Interlock Installation Facilitation                     | New section added, Alcohol Interlock Installation Facilitation              |
|          |     |     | 41       | 4.5.3 handrail/stanchion construction and installation                | Vertical handrail requirements updated                                      |
|          |     |     | 58 to 62 | 8.3 Heating, Ventilation & Air Conditioning (HVAC)                    | Update to HVAC requirements   |
|          |     |     | 72       | 10.3 Other internal and external signs and notices                    | Link to latest Bus Graphics Standard updated                                |
|          |     |     | 74       | 10.5 Paints colours and Livery  | Link to latest Bus Graphics Standard updated                                |
|          |     |     |          | Attachment 6: Standard for the Fire Retardant Properties of Materials | Definition of engine bay added, compliance requirements updated             |



|                 |            |            |          |   |  |
|-----------------|------------|------------|----------|---|--|
|                 |            |            |          | Attachment 9: Heating Ventilation and Air Conditioning (HVAC)         | Updated test procedure to reflect changes to specification   |
|                 |            |            |          | Attachment 15: Advanced Emergency Braking Assessment Protocol         | Scoring and weighting amendments amended   |
|                 |            |            |          | Attachment 16: Advanced Emergency Braking Guidance Notes              | False Positive requirements updated  |
|                 |            |            |          | Attachment 17: Intelligent Speed Assistance (ISA) Assessment Protocol | Amendment to section 9.1.3.3 b)  |
|                 |            |            |          | Attachment 34: Occupant Friendly Interiors Assessment Protocol        | Normative references updated   |
|                 |            |            |          | Attachment 42: Complex Eletronic Control Systems                      | New Attachment created to facilitate Attachments 15 & 16   |
| <b>Mar 2023</b> | <b>872</b> | <b>2.4</b> | 8        | 3.2.1 Testing and Certification Requirements                          | Definition of Test Service added   |
|                 |            |            | 9 to 12  | 3.2.2 Compliance Carryover Between Vehicle Types and Variants         | Table 3_2 added, detailing evidence requirements when compliance carryover is intended   |
|                 |            |            | 15 to 16 | 4.1.1 Smoke Detectors   | Update to smoke detector requirements, increase in quantity and scope of smoke detectors, Emergency Shutoff button scope and wording |
|                 |            |            | 23 to 24 | 4.3.3 Intelligent Speed Assistance (ISA)                              | Updates to ISA symbol light colour requirements.<br>Update to ISA system logic requirements through removal of 'Option 1' logic      |
|                 |            |            | 34 to 35 | 4.3.5.3 Brake toggle system   | Update and clarification to system logic   |
|                 |            |            | 36 to 40 | 4.3.6 Runaway Bus Prevention  | Changes to Runaway Bus Prevention system logic and performance requirements  |



|  |  |  |            |  |   |
|--|--|--|------------|--|---|
|  |  |  | 40         | 4.3.7 Halt Brake                                     | Update to definition and clarification of functionality   |
|  |  |  | 51         | 4.6.1 VRU Frontal Crashworthiness: Minimum Geometry  | Clarifying wording added to use of 236 mm x 236 mm probe for measuring global geometry angles                         |
|  |  |  | 53         | 4.6.2 VRU Frontal Crashworthiness: Enhanced Geometry | Clarifying wording added to use of 236 mm x 236 mm probe for measuring global geometry angles                         |
|  |  |  | 55         | 4.7.1 Rescue Sheet & Emergency Rescue Guide (ERG)    | Emergency rescue guide requirement added  |
|  |  |  | 56         | 4.7.2 Rescue Sheet and ERG Storage                   | Rescue sheet and Emergency rescue guide requirements added  |
|  |  |  | 59         | 5.2 Air quality and emissions                        | Vehicle Idle shutdown requirement scope updated to include EV buses   |
|  |  |  | 73         | 8.3.1 Drivers Cab                                    | Updates to HVAC performance requirements  |
|  |  |  | 74         | 8.3.2 Passenger Saloon                               | Updates to HVAC cooling and heating and performance requirements  |
|  |  |  | 79         | 8.3.3 HVAC Test Switch                               | Addition of a test switch for in service performance monitoring   |
|  |  |  | 79         | 8.3.4 Thermal Insulation                             | Updates to HVAC insulation performance requirements   |
|  |  |  | 35         | Attachment 6   | Update to RESS compliance level and timings   |
|  |  |  | 117 to 137 | Attachment 17  | Inclusion of audible alert check, ISA status symbol colours and test procedure to reflect amendments to specification |
|  |  |  | 137 to 140 | Attachment 18  | Updated to to reflect amendments to specification and Attachment 17   |
|  |  |  | 228 to 239 | Attachment 26  | Amendments to ALS test requirements and BTS requirements, including addition of a reverse gear test scenario          |
|  |  |  | 239 to 246 | Attachment 27  | Amendments to guidance notes to reflect changes to assessment protocol and specification                              |



|                 |            |            |            |    |  |  |
|-----------------|------------|------------|------------|----|--|--|
|                 |            |            | 246<br>255 | to | Attachment 28                                | Amendment to Runaway Bus Prevention assessment protocol to reflect changes to specification requirements |
|                 |            |            | 255<br>258 | to | Attachment 29                                | Amendments to guidance notes to reflect changes to assessment protocol and specification                 |
|                 |            |            | 282<br>303 | to | Attachment 34                                | Updated assessment protocol procedure for useability and clarity   |
|                 |            |            | 303<br>307 | to | Attachment 35                                | Amendments to guidance notes to reflect changes to assessment protocol                                   |
|                 |            |            | 330        |    | Attachment 37                                | Correction to lower impact speed   |
|                 |            |            | 356        |    | Attachment 40                                | Guidance added regarding advised vehicle extension lengths   |
| <b>Apr 2024</b> | <b>913</b> | <b>2.5</b> | i to ii    |    |  | Version updated  |
|                 |            |            | 4 to 5     |    | 2: Status of Application of Requirements     | Pedal acoustic feedback requirement year updated, Emergency stop signal safety measure added             |
|                 |            |            | 8          |    | 3.1 Regulatory and TfL compliance            | PSVAR2023 requirement added  |
|                 |            |            | 10 to 13   |    | 3.2.1 Testing and Certification Requirements | Attachment 43 added to table 3_1, table 3_2 compliance carryover updated                                 |
|                 |            |            | 19 to 20   |    | 4.2.3 Vehicle Security Enhancement           | New requirement added  |
|                 |            |            | 20         |    | 4.3.1.1 Acceleration Rate Compliance         | New assessment protocol, attachment 43 referenced  |
|                 |            |            | 26         |    | 4.3.3.3 GPS Accuracy and Driver Warnings     | Section updated  |
|                 |            |            | 28         |    | 4.3.3.5 Over The Air (OTA) Updates           | Over the air updates requirement added   |
|                 |            |            | 33 to 34   |    | 4.3.4.5 Front & Nearside Blind Spot Warnings | Requirement amended  |
|                 |            |            | 38         |    | 4.3.5.4 Pedal acoustic feedback system       | Requirement amended to reflect current research status   |



|  |  |  |          |  |  |
|--|--|--|----------|--|--|
|  |  |  | 39       | 4.3.5.5 Pedal Standardisation &<br>4.3.5.6 AEB logic         | Requirement amended to reflect current research status       |
|  |  |  | 45       | 4.3.10 Emergency Stop Signal                                 | New requirement added  |
|  |  |  | 45 to 48 | 4.4.1 Acoustic Conspicuity                                   | Amendments to requirement throughout                         |
|  |  |  | 49       | 4.5.1.1 Staircase Nosing<br>Lighting                         | New addition to reflect current customer experience research |
|  |  |  | 49       | 4.5.2.1 High Back Seats                                      | New addition to reflect current customer experience research |
|  |  |  | 50       | 4.5.3 Handrail/stanchion<br>construction and installation    | Reference to other relevant sections added                   |
|  |  |  | 52       | 4.5.6.1 Flooring Appearance                                  | New addition to reflect current customer experience research |
|  |  |  | 52 to 56 | 4.5.7 Door Safety  | New requirement added  |
|  |  |  | 59       | 4.6.3 VRU Frontal<br>Crashworthiness: Energy<br>Absorption   | Test HIC <sub>15</sub> and BITS requirements amended         |
|  |  |  | 59       | 4.6.4 VRU Frontal<br>Crashworthiness: Wiper<br>Protection    | New bus requirement amended                                  |
|  |  |  | 60 to 61 | 4.7.1 Rescue Sheet (RS) &<br>Emergency Rescue Guide<br>(ERG) | Requirement amended  |
|  |  |  | 70       | 7.1.1 Priority and Preferential<br>Seating                   | Requirement amended for clarity                              |
|  |  |  | 70 to 72 | 7.1.2 Seating Demarcation                                    | New requirement added  |
|  |  |  | 73 to 74 | 7.2.2 Ramp Edge Protection<br>Requirements                   | New requirement added  |
|  |  |  | 76       | 7.4 Bell Pushes and<br>Handpoles                             | Requirement amended for clarity                              |
|  |  |  | 76 to 77 | 7.5.2 Induction Loop<br>Documentation and Testing            | Required standards updated                                   |



|  |  |  |                                  |   |  |
|--|--|--|----------------------------------|---|--|
|  |  |  | 77                               | 8.2.1.1 Skylight Roof   | New addition to reflect current customer experience research   |
|  |  |  | 78                               | 8.2.2 On Board Next Stop Signs (OBNSS) and Information Displays       | Requirement added in line with PSVAR2023, New addition to reflect current customer experience research |
|  |  |  | 78 to 86                         | 8.3 Heating, Ventilation & Air Conditioning (HVAC)                    | Requirement amended  |
|  |  |  | 87                               | 8.4.1 General Seating Requirements                                    | New addition to reflect current customer experience research   |
|  |  |  | 87                               | 8.4.1.1 Seat Designs  | Section added and amended for clarity  |
|  |  |  | 87 to 91                         | 8.5 USB Charging Points   | Requirement amended  |
|  |  |  | 92                               | 9.1 Flooring Appearance   | New addition to reflect current customer experience research   |
|  |  |  | 93                               | 10.1 Other Internal and External Signs and Notices                    | Requirement amended to reflect latest graphic standard version   |
|  |  |  | 93                               | 10.1.1 Digital Bus Blinds   | New addition to reflect current customer experience research   |
|  |  |  | 100                              | 10.5 Paint, Colours and Livery  | Requirement amended to reflect latest graphic standard version   |
|  |  |  | 30 to 32                         | Attachment 5: Driver-Passenger Two-Way Communication Protocol         | Amendments to assessment protocol  |
|  |  |  | 34                               | Attachment 6: Standard for the Fire Retardant Properties of Materials | Additional fire barrier requirements added   |
|  |  |  | 41 to 51                         | Attachment 9: Heating Ventilation and Air Conditioning (HVAC)         | Assessment protocol amended to reflect previously released draft version                               |
|  |  |  | 113, 116, 118 to 120, 126 to 127 | Attachment 17: Intelligent Speed Assistance (ISA) assessment Protocol | Amendments and clarifications to assessment protocol   |



|  |  |  |            |   |   |
|--|--|--|------------|---|---|
|  |  |  | 132 to 133 | Attachment 18: Intelligent Speed Assistance (ISA) Guidance Notes                                    | Clarifying amendments   |
|  |  |  | 174 to 187 | Attachment 24: Blind Spot Warning (BSW) Assessment Protocol   | Amended to new assessment protocol  |
|  |  |  | 188 to 193 | Attachment 25: Blind Spot Warning Guidance Notes  | Amended to reflect amendments to attachment 24                            |
|  |  |  | 197        | Attachment 26: Pedal Application Error Assessment Protocol  | Amended to reflect current research programme status                      |
|  |  |  | 211        | Attachment 28: Runaway Bus Prevention Assessment Protocol   | Supporting documents amended to reflect specification requirements        |
|  |  |  | 224 to 234 | Attachment 30: Acoustic Conspicuity Assessment Protocol   | Amended for clarity   |
|  |  |  | 248 to 288 | Attachment 34: Occupant Friendly Interiors Assessment Protocol                                      | Amended for formatting and clarity  |
|  |  |  | 293 to 312 | Attachment 36: VRU Frontal Crashworthiness Energy Absorption Assessment Protocol                    | Assessment protocol amended to reflect recent research programme findings |
|  |  |  | 313 to 320 | Attachment 37: Bus VRU Frontal Crashworthiness Energy Absorption Assessment Protocol Guidance Notes | Amended for clarity and to reflect amendments to attachment 36            |
|  |  |  | 355 to 360 | Attachment 43 - Bus Acceleration Performance Assessment Protocol                                    | New assessment protocol   |





|   |            |
|---|------------|
| <b>Version Control</b> .....  | <b>iii</b> |
| <b>1 Introduction</b> .....   | <b>1</b>   |
| 1.1 Scope .....   | 1          |
| 1.2 Purpose .....   | 1          |
| 1.3 Process.....  | 1          |
| 1.4 Terminology .....   | 2          |
| 1.5 LBSL Approval.....  | 2          |
| <b>2 Status of Application of Requirements</b> .....                | <b>3</b>   |
| <b>3 Regulatory Compliance</b> .....                                | <b>8</b>   |
| 3.1 Regulatory and TfL compliance.....                              | 8          |
| 3.2 Test Process .....  | 9          |
| 3.2.1 Testing and Certification Requirements .....                  | 9          |
| 3.2.2 Compliance Carryover Between Vehicle Types and Variants ..... | 10         |
| 3.3 Vehicles types and variants.....                                | 13         |
| 3.3.1 Type-, variant- and version designations.....                 | 13         |
| <b>4 Safety</b> .....   | <b>16</b>  |
| 4.1 Fire Safety .....   | 16         |
| 4.1.1 Smoke Detectors.....  | 16         |
| 4.1.2 Emergency Stop Button .....                                   | 17         |
| 4.2 Security.....   | 17         |
| 4.2.1 Protecting the driver .....                                   | 17         |
| 4.2.2 Discouraging pickpockets.....                                 | 19         |
| 4.2.3 Vehicle Security Enhancement.....                             | 19         |
| 4.3 Driver Assist.....  | 20         |
| 4.3.1 Acceleration performance .....                                | 20         |
| 4.3.2 Advanced Emergency Braking (AEB).....                         | 20         |
| 4.3.3 Intelligent Speed Assistance (ISA) .....                      | 24         |
| 4.3.4 Direct and Indirect Vision .....                              | 29         |
| 4.3.5 Pedal Application Error.....                                  | 34         |
| 4.3.6 Runaway Bus Prevention .....                                  | 39         |
| 4.3.7 Halt Brake .....  | 43         |
| 4.3.8 Tyre Pressure Monitoring Systems (TPMS) .....                 | 43         |
| 4.3.9 Alcohol Interlock Installation Facilitation .....             | 44         |
| 4.3.10 Emergency Stop Signal.....                                   | 45         |
| 4.4 Partner Assist.....   | 45         |



|            |  |           |
|------------|--|-----------|
| 4.4.1      | Acoustic Conspicuity .....   | 45        |
| 4.4.2      | Visual Conspicuity .....   | 48        |
| <b>4.5</b> | <b>Occupant Protection.....</b>                                    | <b>48</b> |
| 4.5.1      | Staircase .....  | 48        |
| 4.5.2      | Seats .....  | 49        |
| 4.5.3      | Handrail/stanchion construction and installation.....              | 49        |
| 4.5.4      | Guards for exposed seats .....                                     | 50        |
| 4.5.5      | Bus Interior Safety Assessment .....                               | 50        |
| 4.5.6      | Flooring and Slip prevention.....                                  | 51        |
| 4.5.7      | Door Safety .....  | 52        |
| <b>4.6</b> | <b>Partner Protection.....</b>                                     | <b>56</b> |
| 4.6.1      | VRU Frontal Crashworthiness: Minimum Geometry.....                 | 56        |
| 4.6.2      | VRU Frontal Crashworthiness: Enhanced Geometry .....               | 58        |
| 4.6.3      | VRU Frontal Crashworthiness: Energy Absorption.....                | 58        |
| 4.6.4      | VRU Frontal Crashworthiness: Wiper Protection.....                 | 59        |
| 4.6.5      | VRU Frontal Crashworthiness: Mirror replacement Class II CMS ..... | 60        |
| <b>4.7</b> | <b>Miscellaneous Safety features.....</b>                          | <b>60</b> |
| 4.7.1      | Rescue Sheet (RS) & Emergency Rescue Guide (ERG) .....             | 60        |
| <b>5</b>   | <b>Environmental Performance .....</b>                             | <b>61</b> |
| 5.1        | General .....  | 61        |
| 5.2        | Air quality and emissions .....                                    | 61        |
| 5.3        | Carbon Dioxide Emissions .....                                     | 62        |
| 5.4        | Noise emissions.....   | 62        |
| 5.5        | Infrastructure protection .....                                    | 63        |
| <b>6</b>   | <b>Operational Efficiency .....</b>                                | <b>63</b> |
| 6.1        | Vehicle capacity .....   | 63        |
| 6.2        | Energy efficiency – Electric Vehicles.....                         | 66        |
| 6.2.1      | Minimum Charging Requirements .....                                | 66        |
| 6.2.2      | Opportunity Charging .....   | 66        |
| 6.3        | Minimising dwell time.....   | 66        |
| 6.4        | Fleet management .....   | 67        |
| 6.4.1      | CCTV/Audio recording .....   | 67        |
| 6.4.2      | Fleet Management System .....                                      | 67        |
| 6.4.3      | Communications.....  | 67        |
| 6.4.4      | Ticketing.....   | 68        |



|          |   |           |
|----------|---|-----------|
| <b>7</b> | <b>Accessibility</b>                                      | <b>70</b> |
| 7.1      | <b>Seating</b>  | <b>70</b> |
| 7.1.1    | Priority and Preferential Seating                         | 70        |
| 7.1.2    | Seating Demarcation                                       | 70        |
| 7.2      | <b>Ramps</b>  | <b>72</b> |
| 7.2.1    | General Ramp Requirements                                 | 72        |
| 7.2.2    | Ramp Edge Protection Requirements                         | 73        |
| 7.2.3    | Additional notes to manufacturers/suppliers               | 74        |
| 7.3      | <b>Wheelchairs</b>  | <b>74</b> |
| 7.3.1    | Wheelchair Area Dimensions and Appearance                 | 74        |
| 7.3.2    | Wheelchair Area Handrails and Bell Pushes                 | 75        |
| 7.4      | <b>Bell Pushes and Handpoles</b>                          | <b>75</b> |
| 7.5      | <b>Induction Loops</b>                                    | <b>76</b> |
| 7.5.1    | Induction Loop Zones                                      | 76        |
| 7.5.2    | Induction Loop Documentation and Testing                  | 76        |
| <b>8</b> | <b>Occupant Experience</b>                                | <b>77</b> |
| 8.1      | <b>Driver cab ergonomics</b>                              | <b>77</b> |
| 8.2      | <b>Passenger saloon ergonomics</b>                        | <b>77</b> |
| 8.2.1    | Windows   | 77        |
| 8.2.2    | On Board Next Stop Signs (OBNSS) and Information Displays | 78        |
| 8.2.3    | Interior Saloon Lighting                                  | 78        |
| 8.3      | <b>Heating, Ventilation &amp; Air Conditioning (HVAC)</b> | <b>78</b> |
| 8.3.1    | Drivers Cab   | 78        |
| 8.3.2    | Passenger Saloon  | 80        |
| 8.3.3    | Thermal Insulation  | 86        |
| 8.3.4    | General Requirements                                      | 86        |
| 8.4      | <b>Seating</b>  | <b>86</b> |
| 8.4.1    | General Seating Requirements                              | 86        |
| 8.5      | <b>USB Charging Points</b>                                | <b>87</b> |
| 8.5.1    | General Requirements                                      | 87        |
| 8.5.2    | Technical Requirements                                    | 88        |
| 8.5.3    | Electrical Protection                                     | 89        |
| 8.5.4    | Installation of Outlet Units                              | 89        |
| 8.5.5    | Visual Requirements                                       | 91        |
| <b>9</b> | <b>Aesthetics &amp; Image</b>                             | <b>92</b> |



|             |  |            |
|-------------|--|------------|
| <b>9.1</b>  | <b>Flooring Appearance .....</b>   | <b>92</b>  |
| <b>10</b>   | <b>Route and destination board, signs and notices, livery, advertising etc .....</b> | <b>92</b>  |
| <b>10.1</b> | <b>Destination and Route Number displays .....</b>                                   | <b>92</b>  |
| 10.1.1      | Digital Bus Blinds .....   | 93         |
| <b>10.2</b> | <b>Running Numbers .....</b>   | <b>94</b>  |
| <b>10.3</b> | <b>Other Internal and External Signs and Notices .....</b>                           | <b>94</b>  |
| 10.3.1      | First Responders Vehicle Propulsion Identification Symbols.....                      | 95         |
| <b>10.4</b> | <b>External Advertising .....</b>  | <b>99</b>  |
| <b>10.5</b> | <b>Paint, Colours and Livery.....</b>  | <b>100</b> |
| <b>11</b>   | <b>Design for Ease of Maintenance .....</b>  | <b>100</b> |



## 1 Introduction

This document defines LBSL's technical requirements for new buses entering into service in London.

### 1.1 Scope

This protocol applies to all new buses intended for service under contract to LBSL that are passenger vehicles with a maximum mass exceeding 5 tonnes and a capacity exceeding 22 passengers. The passenger vehicles will be capable of carrying seated but unrestrained occupants and standing occupants. Such vehicles are categorised the Consolidated Resolution on the Construction of Vehicles (R.E.3) as M3; Class I.

### 1.2 Purpose

LBSL wishes to promote a world leading bus service in London. As such LBSL has a range of objectives and wishes for all new buses used in London to contribute to the achievement of those objectives:

- Regulatory Compliance
- Safety: TfL and LBSL are committed to Vision Zero and believe that no death or serious injury when travelling in London is either acceptable or inevitable. LBSL's aim is that by 2030 nobody will be killed in a collision involving a bus.
- Environmental Performance: LBSL support the target to reduce the Capital's CO<sub>2</sub> emissions by 60% by 2025 and become carbon neutral by 2050. To have a zero emission at tailpipe fleet by 2037. All new diesel powered buses will incorporate the latest technical designs, and systems to ensure the environmental performance of the vehicle delivers the highest possible sustainable clean energy standards and bus propulsion systems.
- Operational efficiency
- Accessibility: LBSL aim to continue to improve the accessibility of their bus services
- Passenger experience
- Aesthetics and image

This specification is structured to allow LBSL to ensure certain minimum standards are met in relation to its objectives and to easily assess to what extent individual models of bus might exceed those requirements and contribute more to their objectives.

### 1.3 Process

From time to time, LBSL may require additional control systems to be installed, and/or integrated into the base vehicle systems for the purposes of conducting demonstrations and/or trials to test and evaluate new or emerging technologies. The aim of these trials is to achieve the continuous improvement and enhancement of driver and passenger safety/comfort systems, and to ensure road space is shared as safely as possible with other road users. These trials will also develop and promote



innovations in London bus operations, bus design, accessibility features, and the continued reduction in harmful tailpipe emissions.

LBSL prior approval must be agreed for any exemptions/dispensations to allow for controlled deviation from the specified standards and/or performance requirements in this document. Request for exemptions/dispensation must be made in writing to the LBSL Nominated Officer. The reason(s), benefits, and any associated risks from such exemption/dispensation must be identified and assessed with the appropriate mitigations.

## 1.4 Terminology

London Bus Services Ltd (LBSL) is the subsidiary of Transport for London (TfL) that is responsible for the contracting and operation of London's bus network. LBSL and TfL are used interchangeably throughout the document.

The language used in this specification is typical of standards documents and shall be interpreted as follows:

- Mandatory requirements are indicated by phrases such as 'Must', 'Shall' or 'Required'.
- Where requirements are indicated by the word 'should' they are strongly recommended, and applicants shall present strong evidence to justify why their vehicle remains acceptable if these recommendations are not followed.
- Where requirements are indicated by the word 'may' they are optional and deviation is acceptable without presenting additional justification.

In addition to the above, some whole sets of requirements are indicated as being 'preferred'. These requirements are optional at the discretion of the OEM and operator but LBSL reserve the right to employ whatever commercial levers are at its disposal to encourage suppliers to choose to include these requirements and are more likely to select bids that include vehicles meeting the preferred requirements.

Section 4 of this document specifies TfL's safety requirements for all new vehicles. Included are details of requirements for new build vehicles entering the fleet in future years as per the Bus Safety Roadmap, highlighted with *italics*. The implementation timetable for future requirements can be found in Table 2\_1.

The use of square brackets, [ ], indicates TfL's current assumptions and may be subject to change once further development work has taken place.

## 1.5 LBSL Approval

Approvals, changes and dispensations to this specification can only be given by LBSL's Nominated Officer in writing, or through a formal contract award letter issued by the Head of Bus Tendering and Evaluation (Richard Rampton).

The Nominated Officer is Tom Cunnington, Head of Buses Business Development. (Tom.Cunnington@tfl.gov.uk)



## 2 Status of Application of Requirements

Many aspects of this specification are mandatory. However, some items will not become mandatory until a future date. Before that time, some requirements may not be applicable at all, some must be followed if the system is fitted voluntarily, some permitted only as part of a controlled trial and some 'preferred' such that although not mandatory LBSL may employ commercial levers or incentives for buses that do comply with the requirements.

**Table 2\_1: Implementation timetable for actual and planned application of each set of requirements**

| Main section        | Subsection  | 2018                | End of 2019         | 2020      | 2021         | 2022         | 2024         |
|---------------------|---|---------------------|---------------------|-----------|--------------|--------------|--------------|
| <b>Requirements</b> | All   | Required            | Required            | Required  | Required     | Required     | Required     |
| <b>Safety</b>       | 4.1 Fire  | Required            | Required            | Required  | Required     | Required     | Required     |
|                     | 4.2 Security  | Required            | Required            | Required  | Required     | Required     | Required     |
|                     | 4.3.1 Driver Assist: Acceleration   | Required            | Required            | Required  | Required     | Required     | Required     |
|                     | 4.3.2 Driver Assist: AEB  | <i>Not Required</i> | <i>Trial Only</i>   | Preferred | Preferred    | Preferred    | Required     |
|                     | 4.3.3 Driver Assist: ISA  | Required            | Required            | Required  | Required     | Required     | Required     |
|                     | 4.3.4.3 Direct & Indirect Vision: Direct vision score (DVS)                       | <i>Not Required</i> | Preferred           | Preferred | Required     | Required     | Required     |
|                     | 4.3.4.3– Direct & Indirect Vision: Enhanced total Bus vision score (BVS)          | <i>Not Required</i> | <i>Not Required</i> | Preferred | Preferred    | Preferred    | Required     |
|                     | 4.3.4.4 Direct & Indirect Vision: Camera Monitor System (CMS): Mirror Replacement | <i>Not Required</i> | <i>Not Required</i> | Preferred | Required     | Required     | Required     |
|                     | 4.3.4.1 Direct & Indirect Vision: Blind spot mirrors                              | <i>Not Required</i> | Required            | Required  | Not Required | Not Required | Not Required |



| Main section | Subsection  | 2018                | End of 2019         | 2020                | 2021                | 2022                | 2024                |
|--------------|---|---------------------|---------------------|---------------------|---------------------|---------------------|---------------------|
|              | 4.3.4.2 Direct & Indirect Vision: Camera Monitor system (CMS) Reversing         | <i>Not Required</i> | <b>Required</b>     | <b>Required</b>     | <b>Required</b>     | <b>Required</b>     | <b>Required</b>     |
|              | 4.3.4.5 Direct & Indirect Vision: Front & Nearside Blind spot warnings          | <i>Not Required</i> | <i>Not Required</i> | Preferred           | Preferred           | Preferred           | <b>Required</b>     |
|              | 4.3.5.3 Driver Assist: Pedal Application Error – Brake Toggling                 | <i>Not Required</i> | Preferred           | Preferred           | <b>Required</b>     | <b>Required</b>     | <b>Required</b>     |
|              | 4.3.5.5 Driver Assist: Pedal Application Error – Pedal standardisation          | <i>Not Required</i> | <i>Not Required</i> | <i>Not Required</i> | <i>Not Required</i> | <b>Required</b>     | <b>Required</b>     |
|              | 4.3.5.2 Driver Assist: Pedal Application Error – Accelerator light system (ALS) | <i>Not Required</i> | <b>Required</b>     | <b>Required</b>     | <b>Required</b>     | <b>Required</b>     | <b>Required</b>     |
|              | 4.3.5.4 Driver Assist: Pedal Application Error – pedal acoustic feedback        | <i>Not Required</i> | <i>Not Required</i> | <i>Not Required</i> | <i>Not Required</i> | <i>Not Required</i> | <i>Not Required</i> |
|              | 4.3.5.6 Driver Assist: Pedal Application Error – AEB logic                      | <i>Not Required</i> | <i>Not Required</i> | Preferred           | Preferred           | Preferred           | <b>Required</b>     |
|              | 4.3.6 Driver Assist: Runaway Bus Prevention                                     | <i>Not Required</i> | Preferred           | Preferred           | <b>Required</b>     | <b>Required</b>     | <b>Required</b>     |
|              | 4.3.7 Driver Assist: Halt Brake   | <b>Required</b>     | <b>Required</b>     | <b>Required</b>     | <b>Required</b>     | <b>Required</b>     | <b>Required</b>     |





| Main section | Subsection  | 2018                | End of 2019         | 2020                | 2021                | 2022                | 2024            |
|--------------|---|---------------------|---------------------|---------------------|---------------------|---------------------|-----------------|
|              | 4.3.8 Driver Assist: Tyre Pressure Monitoring Systems                 | <i>Not Required</i> | <i>Not Required</i> | <i>Not Required</i> | <i>Not Required</i> | <i>Not Required</i> | <b>Required</b> |
|              | 4.3.9 Driver Assist: Alcohol Interlock Installation Facilitation      | <i>Not Required</i> | <i>Not Required</i> | <i>Not Required</i> | <i>Not Required</i> | <i>Not Required</i> | <b>Required</b> |
|              | 4.3.10 Emergency Stop Signal  | <i>Not Required</i> | <i>Not Required</i> | <i>Not Required</i> | <i>Not Required</i> | <i>Not Required</i> | <b>Required</b> |
|              | 4.4.1 Partner Assist: Acoustic Conspicuity - AVAS                     | <i>Not Required</i> | <b>Required</b>     | <b>Required</b>     | <b>Required</b>     | <b>Required</b>     | <b>Required</b> |
|              | 4.4.2 Partner Assist: Visual Conspicuity                              | <b>Required</b>     | <b>Required</b>     | <b>Required</b>     | <b>Required</b>     | <b>Required</b>     | <b>Required</b> |
|              | 4.5.1 – 4.5.3 Occupant protection: Stairs, Seats, & Handrails         | <b>Required</b>     | <b>Required</b>     | <b>Required</b>     | <b>Required</b>     | <b>Required</b>     | <b>Required</b> |
|              | 4.5.4 Occupant protection: Guards                                     | <i>Not Required</i> | <b>Required</b>     | <b>Required</b>     | <b>Required</b>     | <b>Required</b>     | <b>Required</b> |
|              | 4.5.5 Occupant Protection: Bus interior safety – Level 1 requirements | <i>Not Required</i> | Preferred           | Preferred           | <b>Required</b>     | <b>Required</b>     | <b>Required</b> |
|              | 4.5.5 Occupant Protection: Bus interior safety – Level 2 requirements | <i>Not Required</i> | <i>Not Required</i> | Preferred           | Preferred           | Preferred           | <b>Required</b> |
|              | 4.5.6 Occupant protection: Slip prevention                            | <i>Not Required</i> | <b>Required</b>     | <b>Required</b>     | <b>Required</b>     | <b>Required</b>     | <b>Required</b> |



| Main section                  | Subsection  | 2018                | End of 2019         | 2020                | 2021                | 2022            | 2024            |
|-------------------------------|---|---------------------|---------------------|---------------------|---------------------|-----------------|-----------------|
|                               | 4.6.1 Partner Protection: VRU frontal crashworthiness – Minimum geometry                | <i>Not Required</i> | Preferred           | Preferred           | Preferred           | Preferred       | <b>Required</b> |
|                               | 4.6.2 Partner Protection: VRU frontal crashworthiness – Enhanced geometry               | <i>Not Required</i> | <i>Not Required</i> | <i>Not Required</i> | <i>Not Required</i> | Preferred       | <b>Required</b> |
|                               | 4.6.3 Partner Protection: VRU frontal crashworthiness – Energy absorption               | <i>Not Required</i> | <i>Not Required</i> | <i>Not Required</i> | Preferred           | Preferred       | <b>Required</b> |
|                               | 4.6.4 Partner Protection: VRU frontal crashworthiness – Wiper protection                | <i>Not Required</i> | Preferred           | Preferred           | <b>Required</b>     | <b>Required</b> | <b>Required</b> |
|                               | 4.6.5 Partner Protection: VRU frontal crashworthiness – Mirror Replacement Class II CMS | <i>Not Required</i> | <i>Not Required</i> | Preferred           | <b>Required</b>     | <b>Required</b> | <b>Required</b> |
|                               | Bus Safety Standard Overall Score   | <i>Not Required</i> | <b>Required</b>     | <b>Required</b>     | <b>Required</b>     | <b>Required</b> | <b>Required</b> |
|                               | 4.5.7 Door Safety   | <b>Required</b>     | <b>Required</b>     | <b>Required</b>     | <b>Required</b>     | <b>Required</b> | <b>Required</b> |
|                               | 4.7 Miscellaneous Safety Features   | <b>Required</b>     | <b>Required</b>     | <b>Required</b>     | <b>Required</b>     | <b>Required</b> | <b>Required</b> |
| <b>Environment</b>            | All   | <b>Required</b>     | <b>Required</b>     | <b>Required</b>     | <b>Required</b>     | <b>Required</b> | <b>Required</b> |
| <b>Operational Efficiency</b> | All   | <b>Required</b>     | <b>Required</b>     | <b>Required</b>     | <b>Required</b>     | <b>Required</b> | <b>Required</b> |
| <b>Accessibility</b>          | All   | <b>Required</b>     | <b>Required</b>     | <b>Required</b>     | <b>Required</b>     | <b>Required</b> | <b>Required</b> |



| Main section               | Subsection | 2018     | End of 2019 | 2020     | 2021     | 2022     | 2024     |
|----------------------------|------------|----------|-------------|----------|----------|----------|----------|
| <b>Occupant Experience</b> | All        | Required | Required    | Required | Required | Required | Required |
| <b>Aesthetics</b>          | All        | Required | Required    | Required | Required | Required | Required |
| <b>Signs</b>               | All        | Required | Required    | Required | Required | Required | Required |
| <b>Maintenance</b>         | All        | Required | Required    | Required | Required | Required | Required |



## 3 Regulatory Compliance

### 3.1 Regulatory and TfL compliance

All vehicles must comply with all legislation applicable for buses driving in London. If there is any conflict between any requirement in this specification and any legislative requirement then the legislative requirement shall take precedence.

All London buses must be registered for road use in the UK. Registration requires that the vehicle must be approved via one of the following approval routes:

- EC Whole Vehicle Type Approval (ECWVTA)
- Small Series Approval (ECSSTA or NSSTA)
- Individual Vehicle Approval (IVA)

LBSL must be provided with a valid certificate of conformity for every vehicle supplied for use on the London bus fleet. LBSL must be notified of any changes to the vehicle design that would breach conformity of production of the vehicle type as approved by the relevant certification body (i.e. VCA if approved in the UK). Any vehicle found to not conform to the approved type shall be notified to LBSL and appropriate actions will be determined following an investigation.

Vehicles approved to ECWVTA do not need to be fully certified to any additional regulations.

Vehicles approved to National Small Series Type Approval or IVA shall in addition demonstrate that they, or the relevant components they are fitted with, also comply with the following regulations:

- UNECE Regulation 118-03 (Revision 02, Amendment 01) , as amended, on the burning behaviour of materials used in the construction of motor vehicles.
- UNECE Regulation 107, as amended, with respect to the fitment and technical standards of fire suppression systems in engine compartments of buses.
- All windows and glazing shall comply with UNECE Regulation 43
- All status and indicator lamps, even those for systems not required by type approval (e.g. pedal confusion indicator lights) comply with the relevant requirements of UNECE Regulation 121.
- The brake system, including all required interlocks and control systems that interact with the brakes, complies with the requirements of UNECE regulation 13
- Engine emissions shall comply with the latest legal Euro requirements for ECWVTA at time of bus certification.

All vehicles, regardless of approval type shall comply with the Public Service Vehicle Accessibility Regulations of 2000 (PSVAR2000) and 2023 (PSVAR2023) as amended in respect of the fitment and technical standards for accessible equipment, systems and designs. Further specific requirements concerning these regulations are detailed within Section 7 and Section 8 respectively.



Compliance with any given regulation, or specific sections of such regulations, shall be demonstrated to LBSL either by providing copies of all relevant certificates of conformity or by providing a formal written declaration that the vehicle is in compliance with the Regulation or the required parts of the Regulation.

Buses shall not be modified between registration and entry into service. If any modifications are made that affect the ability of the vehicle to carry the plated load, or the brake or steering systems or their mode of operation, then the OEM shall submit a Notifiable Alteration to DVSA and obtain approval for the modification.

All buses must comply with all relevant current legislation and take account of any intended legislative discussions that are considered imminent within the first 6 months of the bus's operational life. For clarity, this means within 6 months of the first delivery made as part of each specific order for new buses. It does not relate to when that model of bus first entered service.

LBSL reserves the right to audit any buses entering or already entered into service, costs associated by this, as well as exploratory testing or trials will be borne by TfL.

All costs associated with development and certification of vehicles by OEMs shall be borne by them unless expressly agreed with TfL.

## 3.2 Test Process

### 3.2.1 Testing and Certification Requirements

OEMs and/or bus operators are permitted to be present during preparation and testing but are not permitted to interfere with or adjust the bus without full agreement of the testing service and the relevant approval authority within TfL.

Reference information about the bus will be noted by the test service and recorded on the test certificate issued. Any adjustments will be noted by the testing service.

Laptops must not be connected during certification tests, either via hardware/cabling, or via wireless/telematic connection.

ECU flash file and other control software must be as used in London operation.

Certification tests must be in the same condition and consecutive, when multiple tests are required.

Throughout this specification and the associated Attachments document, where Test Service is used, this refers to an independent Test House, which has and can provide evidence of being UKAS (or equivalent) accredited to carry out ECWVTA.

**Table 3\_1 Testing and certification requirements for relevant requirements.**

| <b>Requirement</b> | <b>Test / Assessment requirement</b> | <b>Evidence requirement</b> |
|--------------------|--------------------------------------|-----------------------------|
| Attachment 1       | Independent Test Service             | Independent Test Report     |
| Attachment 2       | Independent Test Service             | Independent Test Report     |
| Attachment 5       | Independent Test Service             | Independent Test Report     |
| Attachment 6       | Self Assessment                      | Auditable Evidence Pack     |



|               |   |  |
|---------------|---|--|
| Attachment 7  | Independent Test Service or Self Assessment | Independent Test Report or Auditable Evidence Pack |
| Attachment 8  | Independent Test Service or Self Assessment | Independent Test Report or Auditable Evidence Pack |
| Attachment 9  | Independent Test Service                    | Independent Test Report                            |
| Attachment 15 | Independent Test Service                    | Independent Test Report                            |
| Attachment 16 | Self Assessment                             | Auditable Evidence Pack                            |
| Attachment 17 | Independent Test Service                    | Independent Test Report                            |
| Attachment 19 | Independent Test Service or Self Assessment | Independent Test Report or Auditable Evidence Pack |
| Attachment 24 | Independent Test Service                    | Independent Test Report                            |
| Attachment 26 | Independent Test Service                    | Independent Test Report                            |
| Attachment 28 | Independent Test Service                    | Independent Test Report                            |
| Attachment 30 | Independent Test Service                    | Independent Test Report                            |
| Attachment 32 | Independent Test Service                    | Independent Test Report or Auditable Evidence Pack |
| Attachment 34 | Self Assessment                             | Auditable Evidence Pack                            |
| Attachment 36 | Independent Test Service                    | Independent Test Report                            |
| Attachment 38 | Self Assessment                             | Auditable Evidence Pack                            |
| Attachment 39 | Self Assessment                             | Auditable Evidence Pack                            |
| Attachment 41 | Independent Test Service                    | Independent Test Report                            |
| Attachment 42 | Self Assessment                             | Auditable Evidence Pack                            |
| Attachment 43 | Independent Test Service                    | Independent Test Report                            |

### 3.2.2 Compliance Carryover Between Vehicle Types and Variants

Where carryover of compliance between vehicle Types or Variants is intended, evidence of critical Component and/or installation commonality is required to be submitted to TfL for review.

**Any Vehicle Requirements not captured in Table 3 2 below do not allow for any possibility of compliance carryover.**

For the purposes of this section, the following definitions are applied:

- **Type** - refers to a Single or Double Deck vehicle (e.g., Single and Double Deck vehicles are different Types).
- **Variant**- refers to a Single or Double Deck vehicle with a specific layout or length (e.g., 10.3 m and 10.5 m Single Deck vehicles are the same Type, but different Variants).
- **Whole Vehicle** - Testing is undertaken on the Component or system as it is installed in the vehicle. The 'Whole' vehicle must be presented for testing.



- **Auditable Self-Assessment** - a graphical or tabular assessment of interior components or parts, presented as a comprehensive Data Pack.
- **Component (Certification Type)** - Testing may be undertaken on the component only, it is not necessary for the component to be installed in the vehicle if so desired.
- **Component (compliance)** - refers to a specific component or safety feature (e.g., the wheelchair floor logo, AEB system, ISA system, Occupant Friendly Interior Assessment are all defined as Components).
- **Common/Commonality** - the level of similarity between one component, part or layout from one vehicle Type or Variant and another.
- **Full/Fully Common** - where a component, part, layout is identical from one vehicle Type or Variant to the next.
- **Sufficient Commonality** - for some components, where minor differences in shape, layout, position or size exist between one vehicle Type or Variant and another, TfL may accept this as 'Common'.

Where carryover of compliance between vehicle Types or Variants is intended, evidence of critical Component and/or installation commonality is required to be submitted to TfL for review.

**Table 3\_2 Compliance Carryover Requirements between Vehicle Types and Variants**

| Attachment                      | Certification Type & Level            | Compliance Conditions & Exceptions  |
|---------------------------------|---------------------------------------|---|
| 1 - Emissions                   | Whole Vehicle (Type)                  | No carryover of compliance between Types allowed. For Variant compliance a $\pm$ [250] kg Test Mass is allowed, provided all critical propulsion and HVAC components remain fully common  |
| 2 - Noise test                  | Whole Vehicle (Type or Component)     | No carryover of compliance between Types allowed. For Variant compliance carryover is allowed, provided all critical AVAS Components remain sufficiently common and the <b>Worst-case</b> Variant (longest version) is tested.                      |
| 5 - Driver - Passenger Intercom | Whole Vehicle (Component)             | Compliance evidence required per Component only, carryover between Types and Variants allowed per Component provided installation requirements and positions remain sufficiently common   |
| 6 - Fire Retardant Properties   | Auditable Self-Assessment (Component) | Component compliance may be used to cover multiple vehicle Variants and Types where full commonality to a baseline vehicle is shown, deviations from this baseline must reference the baseline assessment and be covered by an appropriate addendum |
| 8 - Hand Rail Layout            | Whole Vehicle (Variant)               | If sufficient commonality of design and placement is evidenced, Component compliance may be used to cover multiple vehicle Variants and Types   |
|                                 |                                       |   |



|                                       |                                   |   |
|---------------------------------------|-----------------------------------|---|
|                                       |                                   |   |
| 9 - HVAC                              | Whole Vehicle (Type or Component) | No carryover of compliance between Types allowed. For Variant compliance carryover is allowed, provided all critical AVAS Components remain sufficiently common and the <b>Worst-case</b> Variant (longest version) is tested.                                |
| 10 - Destination Display              | Component                         | Compliance evidence required per Component only, carryover between Types and Variants allowed per Component provided installation requirements and positions remain sufficiently common   |
| 11 - CCTV                             | Whole Vehicle (Type)              | No carryover of compliance between Types allowed. Carryover between Variants allowed per Component provided installation requirements and positions remain sufficiently common  |
| 15 - AEB                              | Whole Vehicle (Type or Component) | Compliance evidence required per Component only, carryover between Types and Variants allowed per component provided installation requirements and positions remain sufficiently common, and compliance is achieved for the <b>Worst-case</b> Type or Variant |
| 17 - ISA                              | Whole Vehicle (Type or Component) | No carryover of compliance between Types allowed. Carryover between Variants allowed per Component provided critical Component (ISA unit aerial) installation requirements and positions remain sufficiently common   |
| 19 - Bus Vision Score - Direct Vision | Whole Vehicle (Type or Component) | If sufficient commonality of design and placement is evidenced, Component compliance may be used to cover multiple vehicle Variants and Types   |
| 19 - Bus Vision Score - Bus Vision    | Whole Vehicle (Type or Component) | If sufficient commonality of design and placement is evidenced, Component compliance may be used to cover multiple vehicle Variants and Types   |
| 22 - CMS                              | Whole Vehicle (Type or Component) | If sufficient commonality of design and placement is evidenced, Component compliance may be used to cover multiple vehicle Variants and Types   |
| 24 Blind Spot Warning                 | Whole Vehicle (Type or component) | No carryover of compliance between Types allowed. Carryover between Variants allowed per Component provided installation requirements and positions remain sufficiently common  |
| 26 - Pedal Application Error - ALS    | Whole Vehicle (Component)         | Compliance evidence required per Component only, carryover between Types and Variants allowed per component provided installation requirements and positions remain sufficiently common   |
| 26 - Pedal Application Error - BTS    | Whole Vehicle (Component)         | Compliance evidence required per Component only, carryover between Types and Variants allowed per component provided installation requirements and positions remain sufficiently common   |
|                                       |                                   |   |





|  |                                       |   |
|--|---------------------------------------|---|
| 28 - Runaway Bus Prevention                      | Whole Vehicle (Component)             | Compliance evidence required per Component only, carryover between Types and Variants allowed per component provided installation requirements and positions remain sufficiently common   |
| 30 - AVAS  | Whole Vehicle (Type or Component)     | No carryover of compliance between Types allowed. [For Variant compliance carryover is allowed, provided all critical AVAS Components remain sufficiently common and the <b>Worst-case</b> Variant (longest version) is tested.]                    |
| 32 - Anti-Slip Flooring                          | Component                             | Compliance evidence required per Component only, carryover between Types and Variants allowed per component provided installation requirements and positions remain common  |
| 34 - Occupant Friendly Interiors                 | Auditable Self-Assessment (Component) | Component compliance may be used to cover multiple vehicle Variants and Types where full commonality to a baseline vehicle is shown, deviations from this baseline must reference the baseline assessment and be covered by an appropriate addendum |
| 36 - Frontal Crashworthiness - Bus Impact Test   | Whole Vehicle (Type or Component)     | If sufficient commonality of design and construction is evidenced, Component compliance may be used to cover multiple vehicle Variants and Types  |
| 38 - Frontal Crashworthiness - Minimum Geometry  | Auditable Self-Assessment (Component) | If sufficient commonality of design and placement is evidenced, Component compliance may be used to cover multiple vehicle Variants and Types   |
| 39 - Frontal Crashworthiness - Enhanced Geometry | Auditable Self-Assessment (Component) | If sufficient commonality of design and placement is evidenced, Component compliance may be used to cover multiple vehicle Variants and Types   |
| 41 - Frontal Crashworthiness - Wiper Protection  | Auditable Self-Assessment (Component) | If sufficient commonality of design and placement is evidenced, Component compliance may be used to cover multiple vehicle Variants and Types   |
| 42 - Complex Electronic Components               | Auditable Self-Assessment (Component) | If sufficient commonality of design and placement is evidenced, Component compliance may be used to cover multiple vehicle Variants and Types   |

### 3.3 Vehicles types and variants

The variants shall be defined as per Regulation (EU) 2018\_858.

#### 3.3.1 Type-, variant- and version designations

In addition to defining the type vehicle and variant as required by VCA, and generating the associated alpha-numeric TVV code, TfL require an equivalent code for defining different design variations within each variant. This Safety Standard designation shall be assigned to denote the relevant safety features assessed. The purpose is to provide TfL with a clear indication of exactly which safety features are on the bus, and have been assessed against the Bus Safety Standard. The performance of each bus



shall be assessed at each different TVV-SS level, because any additional feature of the SS added will result in a different safety performance.

For a hypothetical example, it might be possible to specify a bus with TVV code Type A, Variant C and Version F with more than one seating and hand rail layout that would score differently in section 4.5 Occupant Protection. Then each different possible layout shall be provided a unique code such that the correct specification can be identified in subsequent operator tenders.

This Safety Standard designation is referred according to the following table:

[Note that this table is subject to change; it needs to be fully defined and agreed between the relevant approval authority within TfL and the Test service.]

**Table 2\_2 Safety Standard designation table**

| Description   |                                     | Code                    |             |
|---|-------------------------------------|-------------------------|-------------|
| Advanced Emergency Braking - any system that is active at speeds of 10 km/h or more and uses information from sensors to detect an imminent collision and, if the driver fails to take appropriate avoidance action, automatically applies sufficient braking to avoid the collision or at least reduce the collision speed |                                     | AEB                     |             |
| Intelligent Speed Assistance – system fitted to a vehicle to restrict its speed to the prevailing speed limit.  |                                     | ISA                     |             |
| Direct & Indirect Vision- the proportion of each assessment zone visible to the driver through the direct & indirect field of view.   | Vision from vehicles                | DIV-VIS                 |             |
|   | Blind spot mirrors                  | DIV-BSM                 |             |
|   | Camera Monitor Systems              | Reversing               | DIV-CMS-REV |
|   |                                     | Mirror replacement      | DIV-CMS-MIR |
|   | Enhanced indirect and direct vision | DIV-INDDIR              |             |
| Front & nearside blind spot warnings  |                                     | DIV-BSW                 |             |
| Pedal Application Error – an incident where a driver mistakenly presses the accelerator pedal instead of the brake pedal.   | Foot placement                      | Footwell camera         | PAE-FPL-CAM |
|   |                                     | Pedal standardisation   | PAE-FPL-STD |
|   |                                     | Brake toggling          | PAE-FPL-TOG |
|   | Driver recovery                     | Pedal Indicator Light   | PAE-REC-PIL |
|   |                                     | Pedal acoustic feedback | PAE-REC-PAF |
| Vehicle intervention  | AEB logic                           | PAE-INT-AEB             |             |
| Runaway Bus Prevention – a bus without the park brake engaged that moves in any direction in an uncontrolled manner without any input from a driver   |                                     | RUN                     |             |
| Halt Brake – an automated braking system that prevents a bus from moving under certain conditions.  |                                     | HBR                     |             |



| Description   |                                | Code              |            |
|---|--------------------------------|-------------------|------------|
| Tyre Pressure Monitoring System – a system fitted to a bus to warn the driver when a loss of pressure occurs in a tyre  |                                | TPMS              |            |
| Alcohol Interlock Installation Facilitation - is a standardised interface that facilitates the fitting of aftermarket alcohol interlock devices in motor vehicles |                                | AIIF              |            |
| Acoustic Conspicuity - systems is to make a quiet running vehicle (e.g. hybrid or electric) as conspicuous to a pedestrian as a typical diesel engine.            |                                | ACO               |            |
| Visual Conspicuity - systems is to make a vehicle more visually conspicuous to a pedestrian.  |                                | VCO               |            |
| Occupant Protection – identification of injury hazards present in the vehicle with the objective of encouraging safer vehicle designs                             | Staircase                      | OCC-STR           |            |
|   | Seats                          | OCC-SEA           |            |
|   | Handrails                      | OCC-HDR           |            |
|   | Guards for exposed seats       | OCC-GRD           |            |
|   | Bus Interior Safety Assessment | OCC-BISA          |            |
|   | Flooring and slip prevention   | OCC-FLR           |            |
|   | Door safety                    | OCC-DOOR          |            |
| Partner Protection - the impact protection provided by the front end of a bus in the event of a collision with a pedestrian                                       | VRU Frontal Crashworthiness    | Minimum geometry  | VCW-GEOMIN |
|   |                                | Enhanced geometry | VCW-GEOENH |
|   |                                | Energy absorption | VCW-NRG    |
|   |                                | Wiper protection  | VCW-WIP    |
|   | Class II CMS                   | DIV-CMS-MIR       |            |
| Miscellaneous   |                                | MISC              |            |



## 4 Safety

### 4.1 Fire Safety

All materials used in the construction of the passenger saloon and structure separating the saloon from the engine compartment must meet the fire-retardant standards defined in Attachment 6.

Engine and combustion heater compartments shall be equipped with a fully automatic fire suppression system compliant with UNECE Regulation 107 (As Amended). It shall be capable of rapid deployment to extinguish a fire before passenger safety is compromised or serious bus damage is sustained. All vehicles shall have a Regulation 107 compliant system, regardless of powertrain, including zero emission vehicles.

On bus start up, the fire suppression system shall provide the driver with audible notification that it is operative and free from defect.

OEMs shall complete a full fire risk assessment for each type of bus covering as a minimum the engine bay and combustion heater compartment. This should be undertaken in conjunction with the Fire Suppression System (FSS) manufacturer, where this is not the bus OEM, and Bus operators who have the necessary expertise. The outputs from the risk assessment should identify all potential sources of fire and identify the type and location of fire detection devices and fire suppressant dispensing outlets. It should also define the FSS maintenance requirements.

All identified potential sources of fire in the engine bay shall be protected by an effective FSS. This includes any at risk areas behind the engine such as starter motors or filter assemblies. This may increase the length of the trace tube or require additional nozzles. It may also require larger capacity fire suppression cylinders.

The system shall provide accurate and early detection of fires, and multi point dispensing of fire suppressant material targeted at high-risk sections of the engine bay. Manual activation or override by the driver shall not be permitted.

On detection of a fire, the systems shall:

- Provide the driver with immediate audible notification of fire detection;
- Shut off fuel supply to the engine bay and effectively isolate the fuel tank; and
- Remove power to the cooling fan

#### 4.1.1 Smoke Detectors

All bus types shall be equipped with concealed smoke detectors, located as per Figure 4\_1 below.

- Double-deck buses shall be equipped with 3 concealed smoke detectors.
  - 2 detectors on the upper deck
    - 1 located at the front
    - 1 located at the rear
  - 1 detector shall be located on the lower deck at the rear of the seated area

- Single deck buses shall be equipped with 1 concealed smoke detector at the rear of the seated area

All smoke detectors on all bus types shall be located in the approximate area shown in Figure 4\_1. No smoke detector is to be positioned less than 100 mm from any vertical surface.

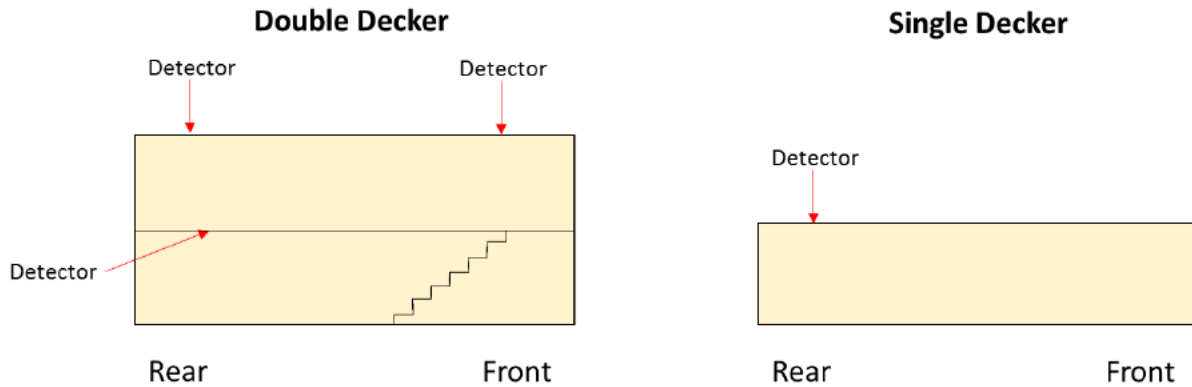

**Figure 4\_1 Smoke detector location requirements for Single and Double Deck vehicles**

An audible and visual warning shall clearly inform the driver of the activation of any detector.

#### 4.1.2 Emergency Stop Button

The legally required manual engine emergency shut down device must be accessible without the need to open the main engine bay cover. It must also be of a type that allows the engine to be restarted from the driver's cab, provided the main rear engine bay cover is closed. The main engine bay cover must be kept locked when the bus is in service.

For vehicle types that have a high voltage system, shutdown shall mean shutting down and isolation of the high voltage system.

**NOTE: For the purpose of this requirement engine and engine bay mean the vehicle powertrain system and locale, and shall apply to all powertrain types.**

The OEM shall demonstrate compliance with these requirements by providing copies of the risk assessments to LBSL.

## 4.2 Security

### 4.2.1 Protecting the driver

All buses shall be fitted with a partition screen separating passengers and the driver.

The driver partition screen shall not include speech holes. The design must allow adequate two-way driver/passenger communication that is accessible to all customer groups. This can be achieved with or without additional communication devices, such as passive or electronic two-way communication systems, and shall be certified in accordance with Attachment 5: Driver-Passenger Two way Communication Protocol.



The driver's partition screen, including its mountings, the structures supporting it and the hinges and catches forming part of any section designed to open to allow driver access and egress, shall be designed to:

- Protect the driver from sustained physical attack from any person.
- Reduce substantially the driver's exposure to pathogen contaminated respiratory droplets and aerosols.
- Minimise the likelihood of a pressurised spray and/or fluids directed at the screen from passing through at any point.
- Be tamper proof with all critical components designed to be difficult to forcibly remove.

The screen, and any communication system hardware mounted in it, shall:

- Be free from rattles during normal driving.
- Not have any uncovered openings or holes.
- Not have doors, hatches, flaps or covers that can be opened or removed without the use of tools or keys.
- Be fitted with a flexible seal, draught seal or other flexible arrangement to close gaps where they exist, including those around its outer edges, around the driver's door and near equipment.
- Be easy to clean and provide adequate access to do so.

For vision assessment:

- The screen shall not restrict or distort driver view to passenger entrance, interior and exterior mirrors or forward exterior view.
- The screen shall be made of transparent materials with a transmittance value of >70 %.
- For clarity, the screen shall be included in the Bus Vision Standard Test and Assessment Protocol, Attachment 19.
- The screen shall be free of substantial reflections and will be assessed for glazing angle as per Attachment 19.
- Fixing, joining and sealing materials shall either be similarly transparent to the screen or their area minimised.

Screen materials shall:

- Be impermeable to air.
- Be durable and long lasting.
- Be resistant to discolouration, scoring or cleaning chemical damage.
- Not require regular replacement as part of a maintenance process of equipment, including the Electronic Ticket Machine (ETM) and validator.
- Be rigid material with the relevant markings showing type-approval conformity.
- Resistant to mould growth.



The driver must be further protected by an independent “siren/common network fleet sound” assault alarm also activating the bus hazard lights.

The driver’s cab signalling window shall be resistant to assault or protected by a device resistant to assault.

#### 4.2.2 **Discouraging pickpockets**

Passenger seats shall be suitably designed to restrict the potential of pickpockets to operate whilst utilising the seating immediately rearward.

#### 4.2.3 **Vehicle Security Enhancement**

This section covers the general requirements of bus on board immobilisers on London buses to enhance vehicle security. The immobilising device fitted would prevent bus thefts, a potential trigger for hazardous incidents or misuse. Unauthorized attempts to gain access via or defeat the system shall trigger immediate alerts and/or stop the bus from starting up.

##### 4.2.3.1 **Immobiliser Type**

All London buses shall have any level of immobiliser fitted. There is no limitation on which type of immobiliser can be used, but the common types include:

- Touch key
- PIN codes
- Blue tooth/NFC/RFID devices
- Biometric driver face/ fingerprint recognition

**A hidden key switch fitted anywhere in the cab is not considered as an approved type of immobiliser.**

##### 4.2.3.2 **System Integration an Working Principles**

The immobilisation system shall be integrated into the vehicle's electronic infrastructure. The Engine Control Unit (ECU) or vehicle drive train system, requiring unique authorisation signals like key fobs or codes to enable ignition. A Controller Area Network (CAN Bus) shall serve as the communication protocol between ECUs/ drive system. The OEM shall offer a robust system to be used for London operations and be protected via an encrypted system.

The general required working principle for the system is as follows:

1. The battery main isolator switch shall be turned on.
2. The battery master switch shall be turned on.
3. The vehicle is switched to ignition ON position whereby the vehicle drive system initiates a request for key ID.
4. Key ID received from driver is then sent to drive system which then compares the code with stored values.
5. The vehicle can be started up should the above values match.



Loading up and processing times for the immobilisation system shall not exceed 1 minute, which would affect normal starting time of the bus.

OEMs/ Operators are also preferred to have driver's ID or duty linked to the immobilisation system such that only drivers on their driving duties or specific engineering staff can start and drive the vehicle at required times. When combined with GPS tracking and alarms, the system can provide protection should the immobiliser fails to prevent unauthorized vehicle operation.

#### **4.2.3.3 Additional Requirements**

In addition to satisfying the above requirements, OEMs shall ensure the fitted system shall comply with The Motor Vehicle (Approval) Regulations 1996 Schedule 2 Item 8 for Anti-theft devices.

**Detailed documentation outlining the type and operation of the chosen immobilisation system must be presented to LBSL for approval prior to fitment**

### **4.3 Driver Assist**

#### **4.3.1 Acceleration performance**

The combined engine and transmission acceleration controls shall limit the bus to a rate that provides the driver with adequate driving acceleration in the fully laden condition, whilst not subjecting the passengers to excessive forces that potentially cause the passengers to become unstable.

##### **4.3.1.1 Acceleration Rate Compliance**

The maximum rate of acceleration shall be less than  $1.2\text{m/s}^2$  under all load conditions when tested against LBSL Attachment 43: Bus Acceleration Performance Assessment Protocol.

#### **4.3.2 Advanced Emergency Braking (AEB)**

*This requirement only applies to new vehicles entering the fleet from 2024 as per the Bus Safety Roadmap for new build buses*

It should be noted that AEB is intended to operate only in the last second or two before an imminent collision. The driver remains responsible for all aspects of driving, including collision avoidance, at all times.

##### **4.3.2.1 Requirements**

Buses shall be fitted with AEB systems complying with the following requirements:

- It shall be tested in accordance with LBSL's Advanced Emergency Braking Assessment Protocol (Attachment 15) and it must attain a performance score greater than [30] %.
- As from 2027, the minimum score shall be increased to a level to be confirmed after consideration of data from monitoring of in-service performance, in particular, the frequency and consequences of false positives.
- Buses equipped with AEB shall experience false positive brake applications less frequently than once every [300,000] km on average.





- The system shall provide the driver with a status indicator that will inform the driver if the system is unavailable for any reason, or if performance is degraded because of imperfect conditions such as sensor misalignment. Where this occurs, the system shall fail to a standard equivalent to an identical vehicle not fitted with AEB. The warning light illuminated in such cases shall be amber.
- The bus OEM must make signals regarding AEB function available for recording by the CCTV system (specified separately) and/or any other appropriate data recording device specified by the vehicle operators. These signals shall at all times indicate the status of the AEB system as follows:
- Enabled, manually deactivated (if any deactivated mode, for example for service, is provided) or unavailable (for example due to self-diagnosed defect or adverse weather)
  - Warning active
  - Brake demand active
  - Level of braking demanded

#### **4.3.2.2 Demonstrating compliance with requirements**

Where a manufacturer submits a vehicle for approval under this standard, then they shall supply a full matrix of test results that they expect to achieve in the sign-off test in accordance with attachment 15. This allows the sign-off test to be a validation of the manufacturer's self-certified score such that, assuming the expectations are met, a reduced number of tests is required. The manufacturer shall also ensure that the test activity is supported with any necessary engineering expertise and diagnostic equipment to quickly resolve any technical difficulties with the AEB system, for example, re-setting fail safe mechanisms triggered by multiple AEB activations in a short time.

Manufacturers shall demonstrate compliance with the requirements with an independent test report covering the attachment 15 requirements and by a documentary package produced in compliance with attachment 42 on complex electronic control systems, covering all aspects of the system design, performance and safety concept. In addition to the general requirements of attachment 42, the package should contain evidence to demonstrate that:

- The AEB approved is identified by a robust and transparent system managing the specification of hardware and version of software or firmware involved.
- Where AEB approval is intended to cover a range of bus types, variants or versions, the manufacturer shall consult TfL prior to the commencement of testing or certification to agree the approach. Evidence shall be presented in relation to the type, variant or version that represents the likely worst case performance within the range considering both true and false positive performance. This assessment must consider, as a minimum:
  - The location of the sensors in X, Y and Z axes
  - Any change in specification affecting the response time of the brake system (the time taken between issuing a braking demand and achieving 90 % of the target level of deceleration).



- Any change in the maximum level of mean fully developed deceleration<sup>1</sup> that can be achieved.
- Any change in wheelbase, front overhang, or steering geometry
- Any difference in the performance of sensors intended for the measurement of current, or prediction of future, motion (e.g. steering wheel angle sensors, acceleration or angular rate sensors).
- The design and verification processes employed provide strong evidence that the false positive requirements will be achieved in service.

Where substantial vehicle mileage may be required to prove compliance with the requirement on false positive rate, it is acceptable to use evidence gained during development of the bus and tuning of the AEB algorithm, provided the process can still prove the final algorithm would have produced the required result if it had been in place throughout. It is not essential to undertake a separate certification road trial. One example of an acceptable process is described generically below:

- Physically drive the vehicle in mixed city environment while recording the sensor inputs and AEB decision making and output requests until a false positive occurs at 'X' km.
- Re-tune the algorithm to eliminate the false positive and update the software version
- Re-run the first 'X' km in simulation with the new software version and confirm it now completes the same distance over the same route without any false positive
- Repeat the steps above as needed until the distance accumulated in the trial reaches [750,000] km ([2.5] times the prescribed minimum distance between false positive events).

Manufacturers are free to use a different process but shall show in the documentation package produced in accordance with attachment 41, that the process is at least as robust a verification as that outlined and that any simulation used in the assessment has been proven to correlate well with real world testing.

Manufacturers may, subject to confirmation by TfL, use mileage accumulated in major cities other than London as part of the verification process, provided it can be demonstrated that the cities are comparable in terms of population density, traffic density, road layouts and general environmental complexity.

#### **4.3.2.3 Defining a False Positive**

Time to collision (TTC) is considered critical in the assessment of AEB. TTC is defined as the time within which a collision with another person, vehicle or object will occur if all parties involved maintain the same speed and trajectory.

Where no other person, vehicle or object is on a collision course with the bus, then the time to collision is considered to be infinite.

---

<sup>1</sup> As defined by UNECE Regulation13 as amended.



For the purposes of verification of compliance, a false positive AEB intervention shall be defined as follows:

- The AEB brake command results in a peak deceleration of 1.50 m/s<sup>2</sup> or more:
  - AND**
    - Analysis of the traffic situation shows that the time to collision at the moment the AEB commanded braking exceeded the greater of [1.4] seconds or the calculated TTC at the last point of braking; **OR**
    - Analysis of the traffic situation showed that an alert human driver did not apply the footbrake within [1.2] seconds of the AEB braking command;
- Time to Collision at the Last point of braking is calculated by:

$$TTC = \frac{U}{2a}$$

- Where U is the vehicle speed in the instant immediately before intervention in metres/second and a is the mean braking deceleration that represents the minimum that would be expected to deviate from normal driving, assumed here to be 3 m/s<sup>2</sup>.

TfL acknowledge that it may not be possible for a single definition to reliably categorise every situation that may occur in the real world into a binary assessment of either true or false positive. If manufacturers consider that this definition of false positive unfairly captures events they consider to be true positives in sufficient numbers to significantly affect their ability to pass the requirement, then they may apply for derogation on the basis of a robust evidence case showing why the categorisation of events is incorrect.

#### **4.3.2.4 Monitoring Compliance In-Service**

In addition to proving compliance before entry into service, as defined above, TfL will also monitor compliance in-service. As such, bus operators shall:

- Record an event every time the FCW or AEB is activated. For each AEB event, the braking demand, initial bus speed, peak deceleration, mean deceleration, and final speed when AEB becomes inactive shall recorded, alongside the total time duration of the event and true false markers to identify:
  - Was the brake pedal pressed at the moment of AEB activation
  - If not, was the brake pedal subsequently depressed within 1.2 seconds of AEB activation
  - Was the accelerator pedal depressed at the moment of AEB activation
  - Was the accelerator pedal depressed after AEB activation but within 1.2 seconds of AEB activation.
- Provide data to TfL, no less frequently than once per 4 week reporting period, defining the absolute number of AEB interventions and the rate per km of the interventions for all buses of the type, variant or version covered by this approval, divided into categories of peak deceleration in accordance with Table 4\_1 below.



| Intervention type   | Number of interventions | Rate of interventions (number per bus km) |
|---|-------------------------|---|
| Forward collision warning only                                |                         |   |
| Braking intervention 0 m/s <sup>2</sup> to 1 m/s <sup>2</sup> |                         |   |
| Braking intervention 1 m/s <sup>2</sup> to 2 m/s <sup>2</sup> |                         |   |
| Braking intervention 2 m/s <sup>2</sup> to 3 m/s <sup>2</sup> |                         |   |
| Braking intervention 3 m/s <sup>2</sup> to 4 m/s <sup>2</sup> |                         |   |
| Braking intervention 4 m/s <sup>2</sup> to 5 m/s <sup>2</sup> |                         |   |
| Braking intervention 5 m/s <sup>2</sup> to 6 m/s <sup>2</sup> |                         |   |
| Braking intervention 6 m/s <sup>2</sup> to 7 m/s <sup>2</sup> |                         |   |
| Braking intervention 7 m/s <sup>2</sup> to 8 m/s <sup>2</sup> |                         |   |
| Braking intervention 8 m/s <sup>2</sup> to 9 m/s <sup>2</sup> |                         |   |
| Braking intervention > 9 m/s <sup>2</sup>                     |                         |   |

**Table 4\_1 AEB Braking Intervention Summary Table**

- Permanently record [5] minutes of CCTV footage either side of the time of each AEB event, retain such footage for at least [3] years and make it available to TfL for analysis, subject to agreeing legally compliant data share agreements, which shall not be unreasonably withheld.

[TfL reserves the right to withdraw approval for a particular vehicle and/or AEB if in-service monitoring identifies that a system is not compliant with the requirements of this specification by virtue of its design and construction. Allowance will be made for the influence of any issues with in-service maintenance or inappropriate use or abuse that was not reasonably foreseeable by the manufacturer.]

#### 4.3.3 Intelligent Speed Assistance (ISA)

An Intelligent Speed Assistance (ISA) system is an aid to the driver to keep within the speed limit and does not absolve the driver of responsibility for complying with speed limits or selecting the most appropriate speed for the prevailing road conditions, which may be lower than the posted speed limit.

TfL will regularly provide updates of speed limits of all roads through the TfL Digital Speed Map (see map management section of this document). The TfL Digital Speed Map incorporates all public highways in every London borough.

The ISA Software version and map version should be accessible either:

- via the vehicle dashboard
- OR
- via use of a Laptop that is connected to the vehicle CAN Bus



All OEMs shall register the fleet number, vehicle registration number and ISA unit serial number with the ISA unit manufacturer prior to installation.

Where new buses are equipped with an Intelligent Speed Assistance system, it shall:

- Operate at all times when travelling on any public highway defined by the TfL Digital Speed Map of London.
- Limit the vehicle speed to the prevailing speed limits as indicated by the TfL Digital Speed Map. When the vehicle is prevented from exceeding the relevant speed limit, this shall be termed the Restricted Operating Mode (ROM).
- Be tested in accordance with the procedures defined in LBSL's Intelligent Speed Assistance Assessment Protocol (Attachment 17) and achieve a 'Pass'.
  - NOTE: OEMs shall contact ISA unit manufacturer prior to either the track test OR London road test to perform a remote health check on the system and to ensure the correct map is installed.
- Have no adverse effects on the fuel consumption or emissions.

#### **4.3.3.1 Bus Integration**

The system must be fully integrated by the bus OEM. Post vehicle homologation fitment of aftermarket equipment is not permitted.

For buses equipped with iBus 1, ISA can utilise the existing iBus GPS antenna (which provides reception on the L1 band) or any other existing bus architecture. The existing iBus antenna can be utilised through using a Radio Frequency (RF) splitter. The RF splitter is required to be approved for use by LBSL. LBSL accept the locational variance in geographic accuracy this entails will be within a 20-metre tolerance.

For buses equipped with iBus 2, the iBus 2 GPS antenna must also be used to provide the GPS signal for ISA by using an RF splitter. The RF splitter must be approved for use by LBSL.

The system shall obtain the speed of the vehicle from the appropriate Fleet Management System (FMS) data field via the FMS Gateway or directly from the CAN. This shall be the same signal which is reflected on the speedometer visible to the driver.

The FMS & CAN vehicle speed must be sufficiently accurate to comply with the requirements of UNECE Regulation 39 on speedometers.

#### **4.3.3.2 Operational**

When entering a speed limited zone or transitioning to a zone with a lower limit, the vehicle must comply with the following performance specification;

- There shall be no intervention by braking to enforce a speed reduction. Energy recovery and/or engine retardation up to the level where the brake lights would be applied is permitted.
- The system will impose a speed limit as soon as all conditions of ROM are met.



- The driver should be notified of any enforced retardation of the vehicle.

When travelling in a speed limited zone and the vehicle is below the prevailing limit there shall be no change in the vehicle performance characteristics. The vehicle shall remain in a smooth driving style for the sake of passenger comfort.

With a vehicle in ROM the ISA system should guard/mitigate against the vehicle accelerating unexpectedly, if the accelerator pedal is depressed during the transition, when the vehicle either:

- exits a speed limited zone,
- enters a zone with a higher limit,
- or deactivates itself for any reason, for example as a consequence of loss of GPS position or speed signal (however sourced),

then when the vehicle exits a speed limited zone the vehicle shall be returned to normal operating mode.

It shall be possible to disable the speed limiting system when the ignition is on and the vehicle is stationary. This shall be possible for qualified personnel only and not for the driver. As a minimum, the action of disabling the system shall be possible by connecting a suitably equipped laptop to the vehicle. OEMs may also provide an additional means of disabling the system using the fleet management telematics.

#### **4.3.3.3 GPS Accuracy and Driver Warnings**

The driver shall be informed of ISA fitment. This may be via a sticker, light, voice instruction, or other indicator.

In the event of loss of GPS, FMS or CAN speed signal the system will fail safe whereby no digital speed map limit is implemented.

The system shall guard/mitigate against spurious signals/GPS inaccuracy for instances when a vehicle is travelling along parallel roads with varying limits or travelling through complex road junctions.

- OEMs shall also consider the use of wheel-based speed over GPS speed to ensure distance hysteresis will still work and timeout variables can be modified in a timely fashion, even when GPS accuracy is poor, or GPS fix is lost.

Upon traveling within a speed limited zone for a distance of 30.0 m and a time of 5.0 seconds the vehicle shall be identified as being within a speed limit zone and be required to activate a ROM. A time of 3 seconds must not be exceeded before the ROM has been implemented. Therefore, assuming the vehicle speed is greater than 10mph the maximum time before implementing the ROM shall be 8 seconds.

Under the following conditions the ISA system shall display a green continuous dash lamp:

- System installed, functioning correctly and inside speed limited zone.
- Transitioning between speed limited zones.
- Enforcing a speed limit (Restricted Operation Mode).

Under the following conditions the ISA system shall inform the driver via a white light:

- Vehicle in fail safe mode (GPS signal loss)
- Vehicle not within a speed limited zone
- System disabled

Under the following conditions the ISA system must display a continuous amber dash lamp:

- System fault present affecting the operation of ISA
- Vehicle in fail safe mode (CAN and/or FMS communication loss)
- Any other condition resulting in the condition of ROM not being implemented

The ISA symbols shall be:



The speed limit of the current road shall be displayed with a speed limit symbol, for example:



The speed limit indicator is mandatory on all vehicles.

It shall flash to indicate an excess of the speed limit. The 'Image Flashing' section of ISO 15008 shall be adhered to, and a flashing frequency of 1Hz to 5 Hz used.

No audible indicator shall be permitted.

#### **4.3.3.4 Map Management**

TfL shall provide a Digital Speed Map which identifies all speed limited zones to be applied by the ISA system.

The file will be made available in one of the follow formats on request to TfL.

- Shapefile (ESRI)
- MITAB (MapInfo)
- KMZ (Google KML)



- GeoJSON (Geographical Java Script Object Notation)
- Geodatabase (gdb)
- GPKG (Open GeoPackage)

The Bus Operator shall ensure that any updates to the map are uploaded to the vehicle within 5 weeks of being released or constantly through Over The Air (OTA) method.

It is envisaged that TfL will carry out an annual map update to capture changing speed limits. Note: any reduction in carriageway speed limit prior to ISA map update being available, does not absolve the drivers of responsibility for adherence to speed limits or appropriate speed.

Whilst this is envisaged to be the norm, TfL would require operators to maintain the capacity to update maps immediately on an 'extraordinary measures/emergency' basis.

An additional antenna for updating the digital map is prohibited.

Access to the mechanism or ECU for updating the map should be physically protected and not easily accessible to the driver or unqualified personnel. For example, in an office with access control for remote system updates, or behind a locked panel for local updates on a bus.

#### **4.3.3.5 Over The Air (OTA) Updates**

The OEM shall ensure that OTA updates are available for all vehicles, with a Connected Service supplied for the entire vehicle life with LBSL. The Connected Service shall include but not be limited to the following:

- Map updates
- Provision of both firmware and/ or feature updates
- Help desk support including issue management of ISA
- Cyber security features to prevent tampering of firmware or map data

The digital speed map updates must be uploaded using either portable data storage, existing local wi-fi network systems, or via cellular network connection. To be agreed by the OEM and bus operator.

#### **4.3.3.6 System Failure**

In the event of a system failure the system shall notify the driver via displaying an amber light, that the system has a fault. The fault shall be logged in the bus memory until inactive and memory is cleared.

ISA is a driver aid to improve driver performance. Drivers remain capable of driving the vehicle at safe speeds even when the system is unavailable. Thus, system failures or other that lead to an activation of the amber light does not mean the vehicle is unroadworthy (subject to any change in regulation).





#### 4.3.4 **Direct and Indirect Vision**

All buses shall allow the driver to have sufficient vision of their surroundings to allow the execution of all driving tasks required in service in London.

All buses shall have a high standard of direct and indirect vision in areas close to the vehicle where vulnerable road users are at particular risk of collision with a bus performing low speed manoeuvres.

##### 4.3.4.1 **Blind Spot Mirrors**

All buses shall, in addition to the mandatory fields of vision described in UNECE Regulation 46, be able to see two rectangular areas on the ground plane with boundaries defined as described below.

- **Nearside (Left Side) Blind Spot Zone:**
  - a) Forward boundary: parallel to the frontal plane of the bus and 0.5m rearward of the driver's ocular reference point
  - b) Rearward boundary: parallel to the frontal plane of the bus and 4m rearward of the driver's ocular reference point
  - c) Inner boundary: parallel to the longitudinal plane of the bus and passing through the outermost point of the nearside (left side) structure of the bus within the forward/rearward boundaries
  - d) Outer boundary: parallel to the longitudinal plane of the bus and 2m outboard from the inner boundary defined in (c) above.
- **Offside (Driver Side) Blind Spot Zone:**
  - a) Forward boundary: parallel to the frontal plane of the bus and 0.5m rearward of the driver's ocular reference point
  - b) Rearward boundary: parallel to the frontal plane of the bus and 4m rearward of the driver's ocular reference point
  - c) Inner boundary: parallel to the longitudinal plane of the bus and passing through the outermost point of the offside (driver side) structure of the bus within the forward/rearward boundaries
  - d) Outer boundary: parallel to the longitudinal plane of the bus and 2m outboard from the inner boundary defined in (c) above.

These ground plane areas should be measured in accordance with the methods prescribed in UNECE Regulation 46.

The reflecting surface and coefficient of reflection of the mirror achieving visibility of the above zone shall comply with the requirements for a class V mirror in UNECE Regulation 46.

The bus OEM or, where installed as a component on an existing vehicle, the mirror supplier, shall provide documentary evidence of compliance with these requirements.



#### **4.3.4.2 Camera Monitor System (CMS): Reversing**

All buses shall be equipped with a rear-view Camera Monitor Systems (CMS) compliant with UNECE Regulation 158 as amended, for system performance, technical quality and field of view requirements. In order to ensure optimum interaction with the driver, the CMS shall in addition meet the following criteria:

- Rear-view CMS monitor images shall only be visible to the driver when the reverse gear is engaged

The bus OEM or, where installed as a component on an existing vehicle, the CMS supplier, shall provide documentary evidence of compliance with these requirements. Supplier certification or manufacturer self-certification will be accepted.

#### **4.3.4.3 Direct Vision Score (DVS) and Enhanced total Bus Vision Score (BVS)**

*The Direct Vision Score (DVS) requirement only applies to new vehicle entering the fleet from 2021 as per the Bus Safety Roadmap for new buses.*

*The Bus Vision Score (BVS) requirement only applies to new vehicles entering the fleet from 2024 as per the Bus Safety Roadmap for new build buses.*

All buses shall be assessed in accordance with LBSL's Bus Vision Standard Assessment Protocol (Attachment 19), reporting the direct vision performance score (DVS) and overall bus vision standard performance score (BVS) for each bus model or bus model variant (as appropriate).

Direct Vision Score: All buses must meet the minimum direct vision performance score (DVS) requirement of 75 %.

Bus Vision Score: All buses must meet the minimum overall bus vision standard performance score (BVS) requirement of 75 %.

The bus OEM shall provide documentary evidence of compliance with these requirements.

#### **4.3.4.4 Camera Monitor System (CMS): Mirror Replacement**

*This requirement only applies to new vehicles entering the fleet from 2021 as per the Bus Safety Roadmap for new build buses*

All buses shall use Camera-Monitor Systems (CMS) that are compliant with UNECE Regulation 46 to replace physical mirrors on the bus, at least for the Class II and IV fields of vision (FOV) defined by the same Regulation and the blind spot FOV defined by the bus vehicle specifications for blind spot mirrors (section 4.3.4.1).

These requirements shall be evaluated based on the driver's FOV from the ocular reference point as defined by UNECE Regulation 46 (635 mm vertically above the seating reference point specified in Annex 1 of ECE/TRANS/WP.29/78/Rev.6).

In order to ensure the optimum interaction with the driver, the CMS shall meet the following criteria:

- Certified according to UNECE Regulation 46 for all relevant CMS FOV.
- CMS FOVs shall be adjusted by the manufacturer to provide drivers with the relevant FOVs and shall subsequently only be adjusted by trained personnel.



- Images for the offside and nearside FOV shall be presented on the respective side of the driver's ocular reference point.
- The offside CMS monitor shall be located at either Position 1 (on the offside A-Pillar) or Position 2 (inside the offside A-pillar), as illustrated in Figure 4\_2, with Position 1 the preferred location.
- The nearside CMS monitor shall be located between Position A (at the centre-top of the windscreen inside the driver cab), Position B (inside the nearside A-pillar) and Position C (on the nearside side console inside the driver cab), as illustrated in Figure 4\_2, with Position A the preferred location.
- CMS monitors shall be located such that they do not affect the driver's direct field of vision (FOV). When evaluating the direct vision performance of the bus according to the bus enhanced direct and indirect vision standard (see 4.3.7), there shall be no change in the direct vision performance score (DVS) both with and without the CMS monitors installed in their operational positions.
- CMS monitors shall not be located lower than 30 ° below a horizontal plane passing through the driver's ocular reference point.
- CMS monitors shall not be located at an angle greater than 55 ° from a vertical plane formed by the ocular reference point and the neck pivot point (located 98 mm rearward from the ocular reference point in the X axis, see 4.3.7) when rotated in both directions about the neck pivot point.
- Maximum CMS monitor distance from the nearest point of the monitor to the driver's ocular reference point shall be no greater than – Offside: 1.7 m | Nearside: 2.6 m.

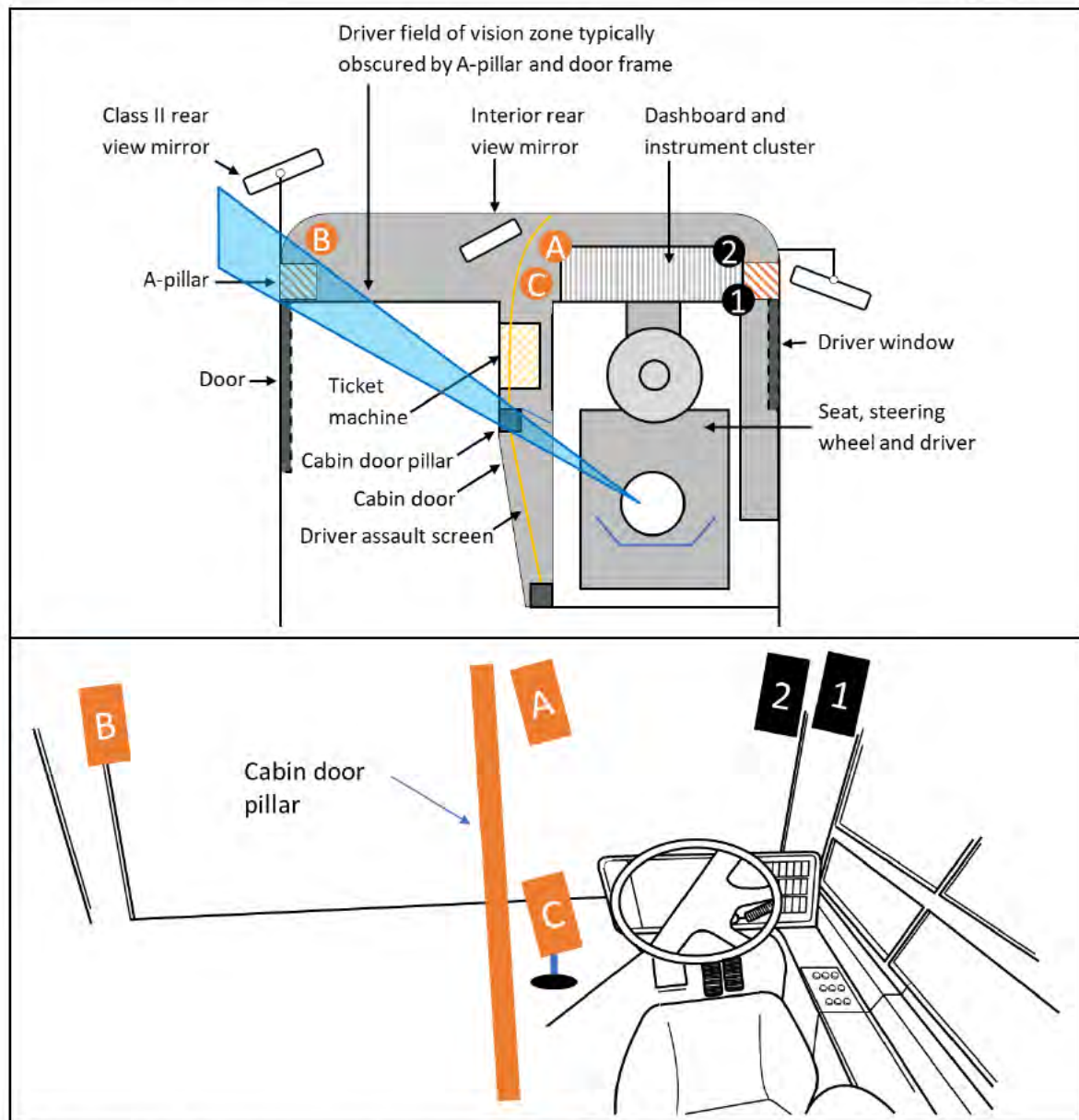

**Figure 4\_2. Recommended offside (1-2) and nearside (A-C) CMS monitor positions**

- Minimum CMS monitor distances from the nearest point of the monitor to the driver's ocular reference point shall be no less than 0.5 m.
- Minimum magnification factors, as evaluated in UNECE Regulation 46, for the Class II monitor shall be at least – Offside: 0.26 | Nearside: 0.13.
- Average magnification factors, as evaluated in UNECE Regulation 46, for the Class II monitor shall be at least – Offside: 0.31 | Nearside: 0.16.
- Minimum magnification factors, as evaluated in UNECE Regulation 46, for the Class IV monitor shall be at least – Offside: 0.054 | Nearside: 0.016.
- Average magnification factors, as evaluated in UNECE Regulation 46, for the Class IV monitor shall be at least – Offside: 0.091 | Nearside: 0.046.
- Non-continuous images on the monitor shall be clearly separated.



- The driver's view of the monitor shall not be obstructed by components with a transmittance of less than 70 %.
- The driver's view of the monitor shall not be obstructed by internal bus glazing with an Angle of Incidence (AOI) of greater than 70 ° to the driver's sightline, when evaluated according to the enhanced direct and indirect vision standard (see 4.3.7).
- CMS monitors shall not obstruct any internal mirrors used for driver visibility of the saloon or wheelchair bay.
- Driver vision of monitors shall not be obstructed by communication holes in driver assault screen.
- Ambient light (e.g. sunlight and artificial light) illuminating the monitor shall be minimised as far as reasonably practical.
- Reflections on bus glazing as a result of the monitor shall be reduced as far as reasonably practical.
- Monitor vibration shall be minimised as far as reasonably practical, with monitor images interpretable up to 90 % of maximum design speed.
- CMS components shall not be located within 5 cm of any radio device emitting electromagnetic radiation in a frequency range that would interfere with the operation of the CMS.
- CMS shall remain fully operational between temperatures of -10 °C and +40 °C with no reduction in image quality
- Driver CMS familiarisation training shall be provided to all drivers and shall include nearside peripheral vision awareness training for nearside monitors positioned in a different location to the traditional nearside external mirror.
- Eye examinations shall be regularly performed for drivers, in particular looking for presbyopia issues which affect eyesight "accommodation" (i.e. the ability of the driver to switch between different viewing distances, which is associated with a decline with age). Corrective lenses, such as bifocal or progressive lenses, shall be provided to drivers that require support.
- The CMS shall be protected from tampering.

The bus OEM or, where installed as a component on an existing vehicle, the CMS supplier, shall provide documentary evidence of compliance with these requirements.

#### **4.3.4.5 Front & Nearside Blind Spot Warnings**

*This requirement only applies to new vehicles entering the fleet from 2024 as per the Bus Safety Roadmap for new build buses*

All buses shall inform drivers of potential hazards presented by vulnerable road users in close proximity to the front and nearside of the bus to support the safe execution of the low speed, close proximity, driving tasks required in service in London.

In order to achieve this, all buses shall be approved by an independent test service in accordance with UNECE Regulation No. 151 on Blind Spot Information Systems and No. 159 on Moving Off Information Systems.



In addition to this, the manufacturer must ensure that the system fitted in order to comply with UNECE Regulation 151 is also effective at informing the driver of a risk of a pedestrian who may be about to cross a side road that the bus is turning into. This shall be demonstrated in accordance with LBSL's Blind Spot Information and Warning Assessment Protocol (Attachment 24), which is based on Annex 4 of UNECE Regulation No. 151, providing an alternative Blind Spot Information Dynamic Test, but adapted to be suitable for a pedestrian situation typical in London, and to stand alone so that it can be read in isolation of the rest of the Regulation.

The bus manufacturer must also ensure that audible warnings from the systems required to comply with the above, in combination with any other driver assist function required by the bus vehicle specification or voluntarily installed by the manufacturer, shall not issue more than [1.5] Audible warnings per [km driven]. This shall be considered as an average over multiple driving shifts and drivers, representative of normal London roads and traffic conditions, but assuming the driver complies with the speed limit. The bus OEM or, where installed as a component on an existing vehicle, the Blind Spot information, Warning and intervention system supplier, shall provide documentary evidence of compliance with these requirements.

#### **4.3.5 Pedal Application Error**

*TfL are currently conducting further research and assessment of data taken from service conditions to develop the requirements, assessment protocols and guidance notes for Pedal Application Error and ensure their suitability. As such this section provides the current expectations, it is however subject to change.*

##### **4.3.5.1 Footwell camera**

A camera shall be installed in the driver footwell area to provide full and uninterrupted coverage of brake and acceleration pedal operation.

The footwell camera shall:

- Maintain good image quality under all lighting conditions, including the capability of operating in "zero lux" conditions (e.g. using infrared if necessary)
- Have a minimum IP65 rating
- Be integrated into the main CCTV recording system to maintain security water marks, consistent time code, date stamp, and bus information (speed, location, and fleet number)
- A separate standalone camera with internal memory card is not permitted

##### **4.3.5.2 Accelerator Light System (ALS)**

This is a driver aid intended to help prevent pedal misapplication and may help recovery from a pedal confusion event. The system has no control over vehicle trajectory or velocity. It does not absolve the driver of responsibility for following safe driving procedures and pressing the correct pedal at all times.

A light-based visual indicator shall illuminate when the accelerator pedal is positioned at >80 % of maximum demand.

The light shall be in a suitable location such as the dashboard or an LCD information screen.

The light shall be large enough, so it is clearly visible from the driver's seat.

The light shall not negatively affect the driver's direct or indirect vision of the road, the cabin or the interior of the bus.

The accelerator light shall be designed and installed such that:

- maintenance and repair is as convenient as possible.
- it complies with to the requirements set out in UNECE Regulation 121. This makes reference to ISO 2575:2004, which should be used as additional guidance if needed. If further guidance is still needed, then the guidance set out in the NHTSA Human Factors Design Guidance For Driver Vehicle Interfaces (DOT HS 812 360) may be referenced as a third option. UNECE Regulation 121 takes precedence in all cases.

The icon presented in Zone A of the bus dashboard must be identical to the icon presented below:



**Figure 4\_3. Pedal indicator icon design**

- The icon must be displayed on a minimum pixel matrix of 32 x 32.
- The icon shall be yellow on a black background.
- All text must be presented on a minimum character matrix of 7 x 9.
- The icon shall not flash or flicker.
- The font of the text is not specified but must be clearly legible (ISO 2575:2010+A7:2017).
  - The text spacing should adhere to the following guidance from ISO 15008:2017: Typefaces selected should be evenly and proportionately spaced.
  - The space between vertical strokes (such as between l and m) should range between 150 % and 240 % of the character stem width.
  - The space between diagonal characters and a vertical (such as between v and l) should be a minimum of 85 % of the stem width (Figure 4-3).
  - Two diagonal characters should not touch.

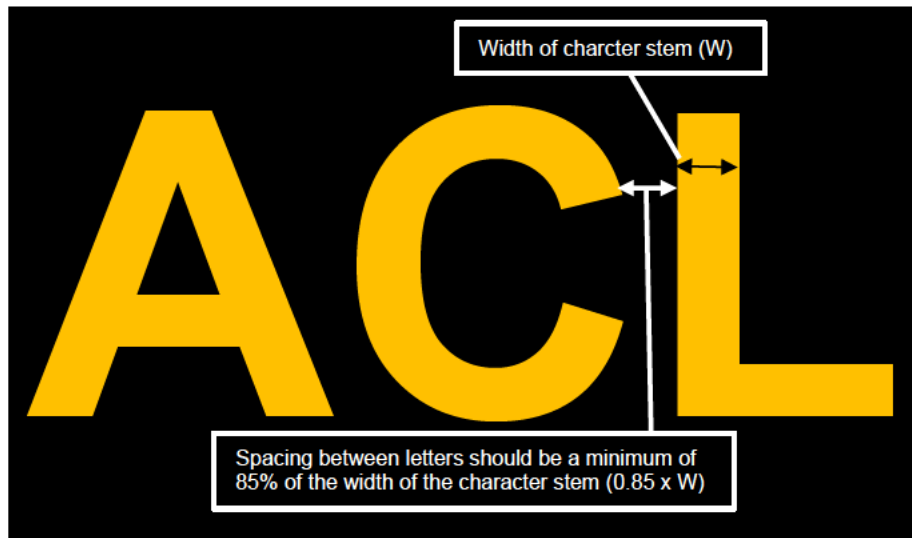

**Figure 4-3 Letter spacing**

The system must be fully integrated by the bus OEM. Post vehicle homologation fitment of aftermarket equipment is also permitted as long as the work is undertaken by the bus OEM.

Information on the position of the accelerator pedal shall be taken from existing on-board sensors via the CAN bus, or some other suitable signal input with an accuracy of  $\pm 1\%$ . (i.e. 80 % accelerator pedal depression  $\pm 1\%$ ).

Any delay between the moment at which the pedal exceeds an application of 80 %  $\pm 1\%$  and the lamp achieving a steady state output which is perceivable by human eye, as a consequence of either delays in electrical transmission of the signal or in terms of the lamps ability to respond quickly to that signal, shall be sufficiently small as to appear instantaneous to the driver.

The Pedal use indicator lights shall

- operate automatically without the need for the driver to activate or deactivate the system.
- operate in all driving scenarios.
- be tested according to the protocol defined in Attachment 26 and be certified as a "Pass".
- have no adverse effects on other vehicle operations and systems.
- not distract the driver from completing their driving tasks.
- illuminate one uniform colour whenever accelerator pedal position is  $>80\%$  of maximum
- not illuminate at a position of  $\leq 80\%$  of maximum accelerator pedal position
- Activate regardless of whether the bus is in Neutral, Drive, or Reverse gear.

Only a qualified and authorised engineer shall be able to disable the system following the procedure set out by the vehicle OEM. It should be possible to shut down the system through a laptop connected to the vehicle.





It shall only be possible to disable the system when the bus is stationary, with the engine switched off and the ignition on.

The system is a driving safety aid. It will be perfectly feasible for a careful and competent driver to drive the vehicle safely without this assistance. As such, a system failure shall not be deemed to render the vehicle unroadworthy (subject to any change in regulation). The system shall be checked as part of the regular maintenance checks.

An audible indicator would be considered by TfL, subject to submission of an example, description of implementation, testing evidence, and quantification of effectiveness. This would only be considered as an addition to the light indicator, not as a replacement.

#### **4.3.5.3 Brake toggle system**

*This requirement only applies to new vehicles entering the fleet from 2021 as per the Bus Safety Roadmap for new build buses*

The brake toggle system is intended to provide a regular refresh of the driver's memory of the use of the brake pedal. The system aims to help prevent pedal misapplication and may help recovery from a pedal application error event. The system has no control over vehicle trajectory or velocity. The driver is ultimately responsible for pressing the correct pedal at all times.

The system is intended to ensure that the brake pedal must be depressed and then released before the bus can pull away from stationary for the first time since the Halt Brake was applied (see Section 4.3.7) or the park brake being applied (whether by the driver or as part of Runaway Bus Prevention; See Section 4.3.6).

The pedal deflection shall be sufficient to trigger the brake lights coming on.

The system must be fully integrated by the bus OEM.

The system shall be integrated with the vehicle's CAN bus, or other suitable information transmission system, so that it can receive the required real-time information on the position of the brake pedal. The signal shall be accurate to  $\pm 1\%$ .

The Brake Toggle System shall comply with steps 1 to 6 below:

1. Operate automatically without the need for the driver to activate or deactivate the system.
2. Be capable of operating in all driving scenarios.
3. Be tested in accordance with the protocol defined in Attachment 26 and achieve a score of 14 (Drive score = 7, Reverse score = 7).
4. Have no adverse effects on other vehicle operations and systems.
5. Ensure that the Halt Brake will release no more than 500 ms, only after the following 2 conditions have BOTH been performed chronologically:
  - I. The brake pedal is depressed enough to trigger the brake lights coming on and then released.AND
  - II. The accelerator pedal is depressed by  $> [10 \ %]$  within  $[10] \ s$  after releasing the brake pedal.



As such, the vehicle shall be incapable of movement until both steps I and II have been successfully completed.

6. Reset the Halt Brake to a 'no drive allowed' condition if the driver does not apply a depression of > [10] % to the accelerator pedal within ≤ [10] s after releasing the brake pedal. This will require the driver to undertake steps I and II again, in order to release the Halt Brake.

**NOTE: The Halt Brake symbol shall illuminate green when the Halt Brake is in a 'drive allowed' condition and Red when the Halt Brake is in a 'no drive allowed' condition**

Only a qualified and authorised engineer shall be able to disable the system following the procedure set out by the OEM. It should be possible to shut down the system through a laptop connected to the vehicle.

It shall only be possible to disable the system when the bus is stationary, with the engine switched off and the ignition on.

The driver shall be warned of a system failure through the activation of a red warning light on the dashboard, and the halt brake light will be sufficient for this purpose.

*[TfL are currently conducting further assessments to define a standardised halt brake red warning light, which may be included in a future issue of this document]*

Any fault with the system shall log a diagnostic trouble code in a suitable memory system at least while the fault is active and preferably for a significant period of time after the fault is active unless manually cleared.

#### **4.3.5.4 Pedal acoustic feedback system**

*This requirement only applies to new vehicles entering the fleet from 2021 as per the Bus Safety Roadmap for new build buses*

**[The Pedal Acoustic Feedback specification and assessment protocol are both currently under development by TfL. At this time system suppliers and OEMs are encouraged to engage with TfL for programme updates, future performance requirements and implementation dates.]**

#### **4.3.5.5 Pedal Standardisation**

*TfL are currently conducting further research and assessment of data taken from service conditions to develop the requirements, assessment protocols and guidance notes for Pedal Standardisation and ensure their suitability.*

*At this time system suppliers and OEMs are encouraged to engage with TfL for programme updates, future performance requirements and implementation dates.*



#### **4.3.5.6 AEB logic**

*This requirement only applies to new vehicles entering the fleet from 2024 as per the Bus Safety Roadmap for new build buses*

*TfL are currently conducting further research and assessment of data taken from service conditions to develop the requirements, assessment protocols and guidance notes for AEB Logic and how it will mitigate Pedal application Error incidents and ensure their suitability.*

*At this time system suppliers and OEMs are encouraged to engage with TfL for programme updates, future performance requirements and implementation dates.*

#### **4.3.6 Runaway Bus Prevention**

*This requirement only applies to new vehicles entering the fleet from 2021 as per the Bus Safety Roadmap for new build buses*

The runaway bus prevention system will not replace the halt brake but instead will work in conjunction with it to automatically stop the bus from moving from a stationary position in the event that a driver is not present in the driving seat (see section 4.3.6.1 below) and the park brake has not been applied.

The system shall be tested in accordance with the assessment protocol defined in Attachment 28 and meet the pass criteria detailed in Attachment 28 – section 8 and 9.

##### **4.3.6.1 Driver Detection Requirements**

###### **Primary Inputs**

Primary inputs are signals broadcast at a high refresh rate that can only be triggered by the driver directly (either by use of hand or foot). They are:

- Accelerator Pedal input
- Brake Pedal Input
- Park Brake

For Primary Status to be 'Driver Detected', a minimum 1 of 3 signals must be in a TRUE or changing state i.e. the driver is applying or lifting their foot off the brake or accelerator pedal

**NOTE: for vehicles with a creep function, this does not qualify as a Driver Detection Accelerator input, only physical application of the Accelerator Pedal qualifies as a Driver Detection Input.**

###### **Secondary Inputs**

Secondary inputs are signals that may change due to non-driver influences (vibration, low accuracy sensors, etc.). They are:

- Driver's cab door sensors
- Driver's seat pressure sensor
- Steering wheel angle



For Secondary Status to be 'Driver Detected', minimum 2 of 3 signals must be in a TRUE or changing state i.e. the Driver's Cab Door is closed and the driver is sitting in their seat, but the driver is not turning the steering wheel

- When Primary or Secondary Status is 'Driver Detected', this indicates that the driver is present in the drivers cab/seat and in control of the vehicle according to that Input.
- When a Primary or Secondary Status is 'Driver NOT Detected' then the Driver is not Present OR not using the vehicle in a safe manner (e.g. driving with the Driver's Cab Door open, or driving while not in their seat).

If some other means to identify the driver presence in the cab is technically preferable by an OEM then this must be submitted with evidence and schematics for consideration by LBSL.

***Any deviations from the prescribed system and assessment protocol requirements must be documented AND agreed in writing by TfL, and added to the test report as an addendum. Any system tested without TfL's prior written approval shall be deemed to be NOT compliant.***

#### **4.3.6.2 System Operation**

The Runaway Bus Prevention system shall function such that it satisfies all of the following conditions:

- Ideal Operation – The Runaway Bus Prevention system may operate in conjunction with the Halt Brake such that when the conditions to activate application of the Halt Brake or Park Brake are met:
  - The Halt Brake application shall be triggered  $\leq [0.5]$  s after Trigger Conditions are met
  - The Park Brake application shall be triggered  $\leq [0.5]$  s after Trigger Conditions are met
  - The vehicle shall come to rest  $\leq [1]$  s after Trigger Conditions are met
- Failsafe Operation - The Runaway Bus Prevention system shall operate in a condition without use of the Halt Brake such that when the conditions to activate application of the Park Brake are met:
  - The Park Brake application shall be triggered  $\leq [0.5]$  s after Trigger Conditions are met
  - The vehicle shall come to rest  $\leq [2]$  s after Trigger Conditions are met
- Audible Operation – When the vehicle speed is  $> 5.5$  km/h AND the conditions to activate application of the Park Brake are met:
  - The system shall trigger an audible warning to the driver  $\leq [0.5]$  s after Trigger Conditions are met

**4.3.6.3 System Hierarchy**

Following the below hierarchy, the system shall:

1. Act in accordance with the System Operation (section 4.3.6.2 above), using both the Park Brake and the Halt Brake. There shall be minimal opportunity for vehicle roll when Runaway Bus Prevention triggers application of the Park Brake while also ensuring that it is not possible for air leakage over time to result in bus movement.
2. Either trigger application of the Park Brake if the driver attempts to switch the vehicle off without first applying the Park Brake, or prevent the driver from switching the vehicle off until they have applied the park brake.
3. Activate application of the Park Brake according to the following manners dependent on the vehicle speed condition:
  - i. Not activate in a situation where the bus is already intentionally in motion (moving > [5.5] km/h). In this condition the system shall trigger an audible alert
  - ii. Activate application of the Park Brake in any situation where the bus is stationary or moving at a speed of  $\leq$  [5.5] km/h.
4. Activate application of the Park Brake or the Audible Alert (determined by Point 3 above) immediately if **ANY** of the following Driver Not Detected Trigger Conditions are met:
  - All monitored Primary **AND** Secondary Status Signals show INACTIVE for a period of [0.5] s

**OR**

  - Primary Status is Driver Detected for the previous [1] s window **AND** Secondary Status is Driver NOT Detected for the previous [3] s window

**OR**

  - Primary Status is Driver NOT Detected for the previous [5] s window **AND** Secondary Status is Driver NOT Detected for the previous [1] s window
5. Require Brake toggling to release under normal use conditions (see Section 4.3.5.3)

**NOTE:**

- i. All signals required to determine driver presence as per the conditions in point 5 and Section 4.3.6.1 must be monitored at all times.
- ii. A window is defined as the rolling time period defined in seconds in point 5
- iii. A Driver Present condition is considered to be met when both the Primary and Secondary status windows show the requisite logic (Driver Detected or Driver not detected) and overlap as per point 5
- iv. If the conditions to trigger activation of the park brake via Runaway Bus are met while the vehicle is travelling at > [5.5] km/h and the vehicle subsequently reduces speed to  $\leq$  [5.5] km/h while the conditions to trigger activation are still met, then the park brake shall be activated immediately.



- v. If the conditions to trigger application of the Park Brake have been met and application of the Park Brake has been initiated, no change in vehicle speed OR Driver Detection status will prevent the Park Brake from being applied

#### **4.3.6.4 Vehicle Creep Function**

If a vehicle has functionality to allow creep, it shall undergo a supplementary set of tests to ensure that in reasonable driving conditions, any creep function shall not cause the vehicle to travel at a speed > [5.5] km/h and not interfere with the correct functioning of the RaBPs.

Vehicle creep does not qualify as a Driver Detection Accelerator input, only physical application of the Accelerator Pedal qualifies as a Driver Detection Input.

#### **4.3.6.5 Auxiliary Release (RaBPS Kill Switch)**

Should a failure be detected in any element of the system while the runaway bus prevention system has already (correctly) activated the park brake, it shall continue to apply the park brake until such time that a qualified person activates or permits activation of the auxiliary release mechanism in order to safely release the bus.

Activation of the Auxiliary Release mechanism shall not require any movement of the vehicle.

The Auxiliary Release switch shall not be positioned in a location that is obvious or allows easy usage by the driver

- This may include requiring a sequence of events to activate the Auxiliary Release, or location of the switch behind a panel not situated within the driver's cab

In the event of a sensor failure that would cause the runaway prevention system to render the vehicle immobile (despite the fact that a runaway bus event is not in progress) the auxiliary release system should be engaged to disable the system and allow the bus to return to the depot to have the sensor repaired/replaced. System checks shall be included in the regular maintenance checks.

The Auxiliary Release system shall deactivate once vehicle is switched back on, after being switched off.

| <b>Vehicle Ignition State</b> | <b>Auxiliary Release State</b>   |
|-------------------------------|--|
| On                            | Auxiliary Release applied while vehicle is on                                |
| Off                           | Auxiliary Release remains applied once vehicle is switched off               |
| On                            | Auxiliary Release deactivates automatically once vehicle is switched back on |

**Table 4\_2: Auxiliary Release Ignition Cycle Process**



#### 4.3.7 Halt Brake

The halt brake shall be engaged whenever the bus doors are opened, the bus is kneeling, or the passenger ramp is extended and the Driver is present in the cab (as defined in section 4.3.6.1).

Once the Halt Brake has been activated the bus shall remain stationary until both:

- The Primary and Secondary 'driver present in cab' conditions for Runaway Bus prevention are met (see section 4.3.6)

AND

- The driver has performed Brake Toggling correctly (see section 4.3.5.3)

The system shall be checked as part of the regular maintenance checks. If a fault occurs with the halt brake system, rendering it inoperable, then a red warning light shall activate. System checks shall be included in the regular maintenance checks.

[TfL are currently conducting further assessments to define a standardised halt brake red warning light, which may be included in a future issue of this document.]

#### 4.3.8 Tyre Pressure Monitoring Systems (TPMS)

*This requirement only applies to new vehicles entering the fleet from 2024 as per the Bus Safety Roadmap for new build buses*

All buses shall be equipped with a Tyre Pressure Monitoring System (TPMS), compliant with 01 series of amendments to UNECE Regulation 141, for the approval of vehicles with regard to their TPMS.

If vehicle already is equipped with either:

- A Tyre Pressure Refill system (TPRS)

OR

- A Central Tyre Inflation System (CTIS)

Then, shall it be deemed to be equivalent to having a Tyre Pressure Monitoring System (TPMS) when the test criteria of Annex 4, 01 series of amendments to UNECE Regulation 141 are met. In this case TPMS is not required to be installed.

The TPMS fitted to a bus provides information to the driver when a loss of pressure occurs in a tyre, by illuminating the indicator light on the dashboard. The TPMS is a driver's aid and does not remove the requirement for maintenance of wheels and tyres.

There are two acceptable TPMS systems:

- i. Direct system - Consists of a TPMS sensor installed directly on to the valve of each wheel. These sensors send information relating to the tyres pressure and temperature in near real time through to the vehicle's Electronic Control Unit (ECU) via Radio Frequency (RF) signals which triggers the illumination of the dashboard indicator light.



- ii. Indirect system – The system uses the vehicle’s Anti-lock Braking System (ABS) sensors to calculate the rate at which each wheel rotates, therefore determining if a tyre has a reduction in pressure in relation to the other tyres. If a tyre’s pressure is low, it will cause the wheel to roll at a different speed to the other wheels. This information when detected by the ECU, will trigger the illumination of the dashboard indicator light

The OEM shall provide documentary evidence of TPMS test results for each of the following:

- Puncture test
- Diffusion test
- Malfunction test

If vehicle is fitted with TPRS or CTIS then the OEM shall provide documentary evidence of test results for both:

- Refill functionality
- Malfunction warning

Tests assessing the performance of Tyre Pressure Monitoring Systems fitted to new buses must be undertaken according to 01 series of amendments to UNECE Regulation 141.

#### 4.3.9 **Alcohol Interlock Installation Facilitation**

*This requirement only applies to new vehicles entering the fleet from 2024 as per the Bus Safety Roadmap for new build buses*

All new buses shall be equipped with the Alcohol Interlock Installation Facilitation. The OEM is required to provide standardised connector facilitation with the installation document for the aftermarket installation of an Alcohol Interlock into vehicle. For this purpose, Alcohol Interlocks are connected to the electric and control circuits of the vehicle.

The OEM is required to provide standardized installation documents in paper or electronic versions, with all necessary relevant information for the technicians installing an Alcohol Interlock into a vehicle, according to EN 50436-7 Alcohol Interlocks – Test methods and performance requirements.

The installation document must contain as a minimum the following:

- Connection schematics – specifying three interfaces to support Alcohol Interlock installation:
  - Classic installation
  - Pseudo-digital installation
  - Digital installation according to EN 50436- 4
- Safety risk at installation and items to be considered
- Assembly instructions
- Modification of vehicle operation





- Mounting position of alcohol interlock handset and the alcohol interlock control-unit

#### 4.3.10 **Emergency Stop Signal**

All new buses shall be fitted with an Emergency Stop Signal (ESS), which are a requirement under the General safety regulation (EU) 2019/2144 as amended.

An ESS is defined as a light-signalling function to indicate to other road users to the rear of the vehicle that a high retardation force is being applied to the vehicle relative to the prevailing road conditions.

All ESSs fitted shall comply with the technical requirements prescribed in UNECE Regulation 48 as amended.

### 4.4 **Partner Assist**

#### 4.4.1 **Acoustic Conspicuity**

All quiet running buses of category M3 are to be fitted with a front emitting Acoustic Vehicle Alerting System (AVAS) which is fully compliant with UNECE Regulation 138. This includes electric, hybrid and other alternative powertrains that are quiet running. This is required even if the bus already meets the minimum sound requirements of UNECE Regulation 138 without the AVAS; an AVAS sound is required on all buses to achieve a uniformity of sound across London.

This specification applies to Existing Fleet Vehicles, Retrofit Vehicles (as defined in the Retrofit programme) and all New Build Vehicles. Performance standards may vary depending on the vehicle category as defined in this document and attachments.

TfL has designed a unique Urban Bus Sound to be used for AVAS on quiet running buses in London and buses belonging to other organisations at TfL's discretion.

##### 4.4.1.1 **System Performance**

The Urban Bus Sound consists of two components, the Core sound and the Beacon sound. TfL will provide Wave (.wav) files containing these components. Playback of the two sound components must be representative of the original files: retaining the same relative amplitude and the same frequency equalisation in all specified operating conditions to comply with this standard.

The Core sound shall be played at all times on bus start up, including when stationary.

The Beacon sound is to be played whenever the bus is in motion regardless of whether the bus is moving forwards or backwards. The Beacon sound shall continue playing until the vehicle comes to a stop.

Seamless transition between the Core and Beacon sounds shall be achieved through synchronised playback of the two Wave files.

##### 4.4.1.2 **Sound Amplitude**

When the Core sound is playing the AVAS must achieve the sound levels ( $L_{AMAX,FAST}$ ) defined in Attachment 30, Appendix B when measured at the positions outlined.

When both the Core and Beacon sounds are playing the AVAS must achieve both the sound levels ( $L_{AMAX,FAST}$ ) defined in LBSL Attachment 30, Appendix B when measured



at the positions outlined, as well as meet the minimum requirements set in Appendix 3 of UNECE Regulation 138.

|   |  |
|---|--|
| Responsive AVAS (Geo-fencing)   | For speeds up to 22 km/h the amplitude of the Urban Bus Sound will be determined by the location of the bus as well as the time of day. This is to be achieved through the AVAS interfacing with the ISA system, which will set the appropriate AVAS Step level profile defined in Appendix B (LBSL Attachment 30) between 0 and 22 km/h. AVAS Step level profiles range between 1 to 4.<br><br>The amplitude shall transition smoothly between roads, taking no more than 3 seconds to transition from one step level profile to another. |
| Non-Responsive AVAS<br>(For Existing Fleet and Retrofit programme vehicles without ISA capability only) | For speeds up to 22 km/h the amplitude of the Urban Bus Sound will be set to AVAS Step level 3 profile defined in Appendix B (LBSL Attachment 30) between 0 and 22 km/h.   |

From 22 km/h the sound must attenuate, decreasing linearly so that the AVAS stops sounding at 28 km/h.

At all times, the Driver's Cabin must not be exposed to sound levels above those set out in LBSL Attachment 30, Appendix B, as a result of sound from the AVAS. Manufacturers are encouraged to further reduce the level of sound ingress to the driver's cabin from the AVAS through system configuration, placement, equipment, sound insulation, or other means, below the maximum levels set out in LBSL Attachment 30.

**4.4.1.3 Frequency Modulation**

The pitch of the Urban Bus Sound must increase at a rate of 0.8% per km/h, for the full speed range of operation, as the bus accelerates and decrease at the same rate as the bus decelerates.

**4.4.1.4 Frequency Profile**

The AVAS shall be capable of shaping the frequency content output by the sounders in order to achieve the desired frequency profile, considering sounder frequency response, positioning and coverings.. This can be implemented either as a hardware or software component of the system.



The Urban Bus Sound must achieve the minimum frequency profiles defined in LBSL Attachment 30, Appendix B for when the vehicle is stationary and when it is moving at the measurement positions outlined.

Sounder technologies for harsh operating environments are continually evolving. Manufacturers are encouraged to develop enhanced frequency response at low and high frequencies for suitable weatherproof sounders in order to improve fidelity of the Urban Bus Sound operating across the TfL bus fleet. The minimum frequency profile in LBSL Attachment 30 shall be updated at regular intervals to respond to improvements in weatherproof sounder performance and improve fidelity of the Urban Bus Sound operating across the TfL bus fleet.

#### **4.4.1.5 AVAS Hardware Requirements**

All AVAS sounders shall be selected for their suitability in terms of achieving the specified performance and for their ability to withstand the environment in which they are located (including protection against ingress of liquids and solids, corrosion/oxidisation/erosion, vandalism, heat/fire resistance). The AVAS sounder(s) shall be rated to IP67 standard or above and located in the area defined in Figure 4\_5.

The system hardware shall be E marked to meet current automotive EMC standards.

A complete functionality self-check of the AVAS must take place on bus start-up, testing hardware and software functionality. The self-check duration and notification shall take no more than five seconds to complete. The system shall provide the driver with a notification that it is operative and free of defects. The Driver shall be informed should the AVAS fail at any time while the bus is switched on by means of a notification. Careful consideration must be given to both the layout to ensure an ergonomical design, and choice of audio/visual alerts/notifications used, to reduce driver movement and any conflicts with other audio/visual systems used.

Responsive AVAS systems shall incorporate a failure mode to allow it to operate at the AVAS Step level 3, as set out in LBSL Attachment 30, Appendix B, in the event that external signals necessary for setting the output amplitude are not received. The UN ECE Regulation 138 requirements shall be maintained at all times.

The capability shall be available to update the system with new sounds to the AVAS hardware, either remotely or with minimal intrusion of the bus so as to prevent buses being unnecessarily taken out of service.

All sound reproduction shall be of a good quality and free from system noise including audible artefacts such as clicks, gaps, hum, distortion effects or clipping. Audio cables shall be separated and suitably shielded from control and power cabling to avoid audible artefacts.

Sounder(s) shall be positioned at the front of the vehicle as a minimum, in the area noted in Figure 4\_5. Sounders shall be positioned in the direction of travel and **not be obstructed by any solid covering** in order to optimise sound projection and directionality (to achieve this, apertures, grilles, perforated front panelling or other aperture types are acceptable), this shall be done while maintaining the sealing integrity of the front of the vehicle.

**Any requirements for apertures, grills, perforations, or other aperture types to the front panelling only applies to New Build vehicles.**

Sounders shall be mounted using appropriate anti-vibration fixings, in order to reduce structure-borne vibration into the Driver's cabin.

Sounder locations are to be selected by the manufacturer to comply with regulatory and LBSL Attachment 30 requirements.

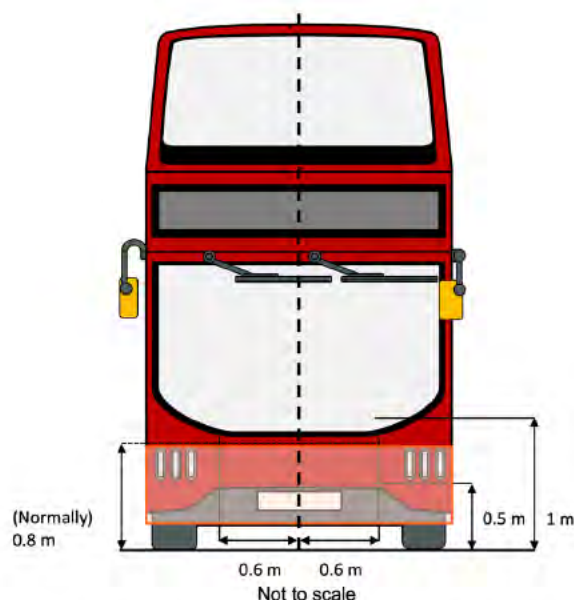

© 2018 TRL Ltd

the future of transport.

**Figure 4\_5 Area at the front of the vehicle that must include at least one AVAS sounder to meet regulatory and Attachment 30 performance requirements**

The AVAS shall be assessed according to LBSL Attachment 30 and be shown compliant.

#### 4.4.2 Visual Conspicuity

The housings for driver's nearside and offside mirrors shall be coloured yellow in their entirety.

No additional warnings or markings shall be present on the all-yellow mirror head.

### 4.5 Occupant Protection

#### 4.5.1 Staircase

Double-decker buses must have a forward ascending 9-step straight staircase with a step tread depth not less than 230 mm, and a step riser of not more than 245 mm located as on the agreed bus layout drawings in Attachment 8.

Handrails must be provided to both sides of staircase, continuous throughout its profile, with no potential hand traps.

An additional offside (body panel side) horizontal handrail on the staircase is required, to improve passengers' handhold options when using the staircase. Attachment 8 shows a typical arrangement as an example.

Exposed butt ends to handrails are not permitted anywhere on the staircase or its access.



Headroom throughout the staircase should be sufficient to minimise risk without the need to provide impact protection.

Finishing edges shall be high quality moulded covers that cope with high passenger volume operation

If transparent materials are used to provide the aisle side staircase panel in the lower salon, it should be of obscured material to achieve a decency screen for staircase users.

If interior panel / corner finishing is utilised, it should be of suitable quality / standard to cope with high wear operation, and if damaged, should not present an immediate increased safety risk.

#### **4.5.1.1 Staircase Nosing Lighting**

[Lighting under Staircase Nosing – specification to be provided in next BVS update]

*The 'Lighting under Staircase Nosing' specification is currently under development by TfL. At this time system suppliers and OEMs are encouraged to engage with TfL for installation requirements and implementation dates.*

#### **4.5.2 Seats**

Tip up seats are not generally permitted anywhere on the bus. However, these will be considered by LBSL where they can demonstrate an improvement in safety and/or customer experience.

Seats should be forward facing, except where the chassis design function over wheel boxes necessitates inward or rearward facing.

**Note: further seating requirements are detailed in Section 7.1 and Section 8.4 of this document.**

#### **4.5.2.1 High Back Seats**

[High Back Seats – specification to be provided in next BVS update]

*The 'High Back Seats' specification is currently under development by TfL. At this time system suppliers and OEMs are encouraged to engage with TfL for installation requirements and implementation dates.*

#### **4.5.3 Handrail/stanchion construction and installation**

All handrails and stanchions shall be constructed such that they meet UNECE Regulation 107 and PSVAR2000 and form a smooth tube of between 30 mm and 35 mm in diameter and finished in powder coating or nylon dipped (both with a matt crackle finish). Handrails and Stanchions should be coloured, yellow (RAL 1028), green (RAL 6018) or orange (RAL 2028). Any alternative colours will require the prior approval of the Nominated Officer.

Staircase handrails shall be of identical cross section to the main saloon handrails

A longitudinal waist height handrail shall be provided, forming a continuous passenger waist height hand grip support from the front passenger door entrance / driver cab area to the beginning of the passenger seated area or staircase steps.



Door partition handrails, positioned to assist boarding and alighting, must be fitted at all entrance and exit points, excluding emergency exits.

Seat back to ceiling handrails (with bell push) are required at all forward facing seat pairs in the lower saloon. In the upper saloon, either seatback to ceiling handrails or a suitable alternative (handgrabs in highback seats etc.) are required at alternate seat pairs as a minimum. On both saloons, where bell pushes are integrated into seatbacks, there shall be a minimum of one bell push per seat pair.

All bell push buttons shall be coloured red with surrounds coloured such that they contrast with both the red bell push and the hand poles, whatever their colour.

Where horizontal handrails are fitted in standing areas, bell pushes, as described above, must be placed in a position so as to limit the risk of accidental activation by passengers leaning on them.

Horizontal rails above the wheelchair and/or standing areas to be fitted with hanging grab hand holds of the flexible type. These grab hand holds shall only be used in the low floor area and must not be placed in entrance / exit doorway areas.

#### 4.5.4 Guards for exposed seats

Guards for exposed seats shall be fitted as per the performance requirements where any seated passenger is likely to be thrown forward into a designated wheelchair space, buggy (pram) space, or open area for standing passengers as a result of heavy braking, as specified in the 06 series of amendments for UNECE Regulation 107.

*Note: The UK DfT proposed this amendment which was adopted as part of the 06 series of amendments, supplement 5. For vehicles approved following EC whole vehicle type approval (ECWVTA), it is expected that these amendments will be mandatory circa 2020. Previously, Regulation 107 specified that guards must be fitted for exposed seats behind step wells, only.*

Guards for exposed seats shall:

- have a minimum height from the floor on which the passenger's feet rest of 800 mm and shall extend inwards from the wall of the vehicle at least as far as 100 mm beyond the longitudinal centre line of any seating position where the passenger is at risk.
- be enclosed (i.e. the size of any aperture shall not exceed 50 mm) and the lower edge of the guard shall not be more than 100 mm from the floor on which the passenger's feet rest.

#### 4.5.5 Bus Interior Safety Assessment

*Level 1 requirement only applies to new vehicles entering the fleet from 2021 as per the Bus Safety Roadmap for new build buses*

*Level 2 requirement only applies to new vehicles entering the fleet from 2024 as per the Bus Safety Roadmap for new build buses*

Bus interior safety shall be assessed according to the protocol defined in Attachment 34. Assessments shall be undertaken for each bus model / variant in a service ready condition.



The bus interior safety assessment score counts potential hazards. Thus, a bus with a lower score, with less potential hazards, is better. Two levels of safety are considered. To be certified as meeting level 1, then the bus must achieve a score of:

- Lower deck  $\leq$  [80]
- AND Upper deck (if applicable)  $\leq$  [8].

*Note: Main changes anticipated are in the middle door area including incorporation of guard in front of seats behind wheelchair area and modifications to guard for seats behind middle doors.*

To be certified as meeting requirements level 2, then the bus must achieve a score of:

- Lower deck  $\leq$  [30].
- AND Upper deck (if applicable)  $\leq$  [4].

*Note: Main changes anticipated are throughout the whole bus to achieve an improved rating for handrails, restraint and general hazards. Improved restraint is also likely to require fitment of some seats with higher backs.*

#### 4.5.6 **Flooring and Slip prevention**

The following requirements apply:

- Floor coverings shall have joints minimised.
- Colour contrasting step nosing shall be used on all step edges in accordance with the PSVAR2000.
- There should be no cross hatching (or any other marking) of the floor area rear of the “Do not stand forward of this point” sign.
- There shall be no cross hatching (or any other marking) of the floor area forward of the “Do not stand forward of this point” sign.
- Slip resistant flooring shall be fitted throughout passenger saloon area.
- The slip resistance of flooring material shall be characterised under wet conditions
- Slip resistance shall be measured at the same location in up to three directions, separated by 45 ° increments as specified in the assessment protocol (Attachment 32).
- All flooring material types, at the point of entering service, shall provide a minimum slip resistance. The material will be deemed a failure if the mean Pendulum Test Value (PTV) is found to be less than 36.0.
- All flooring material types, after approximately 100,000 passengers have accessed the vehicle, or after an in-service period of 6 months, whichever is sooner, shall provide a minimum slip resistance. The material will be deemed a failure if the mean PTV is found to be less than 40.0.
- Thereafter, all flooring material types shall be assessed annually for a period of 7 years from the point of entering service. Throughout this period the material shall provide a minimum slip resistance. The material will be deemed a failure if the mean PTV is found to be less than 40.0.



Floors shall be tested according to the protocol defined in Attachment 32 and achieve a 'Pass'.

Compliance with these requirements shall be demonstrated by providing LBSL with documentary evidence of the performance of flooring material types in the form of United Kingdom Accreditation Service (UKAS) certificates.

New materials shall meet the initial and 6 months requirements as above. In addition, evidence shall be submitted that sets out:

- a) suitable evidence of accelerated wear testing that simulates the extended 7-year use, and
- b) a plan to monitor in service collaboratively with an operator for the 7-year period in order to provide evidence as a verification of the actual wear over that 7-year period.

#### **4.5.6.1 Flooring Appearance**

*Alternative customer-friendly flooring designs and colour schemes (e.g. wood-effect flooring) should be considered for installation. In order to maintain consistent quality and accessibility standards across the fleet, all proposed designs must be presented as part of/within GA Drawings to LBSL for approval prior to fitment and implementation.*

#### **4.5.7 Door Safety**

##### **4.5.7.1 All doors**

##### **4.5.7.1.1 Opening and closing**

- The halt brake shall be engaged immediately whenever any passenger door is not fully closed or locked due to; use of driver or emergency control buttons, automated door safety edge detection system activation, or door opening under a fault condition. This includes when the bus is stationary or driving at speeds less than or equal to [5]km/h.
- When the door close process commences, if the door movement is blocked between fully open and to within [11]mm from fully closed, the door must stop and fully reopen automatically. The system shall be capable of detecting a 11mm diameter round test bar trapped within the door when closing at ambient temperature of 20°C.
- In case an object of [11]mm width is not detected statically, to minimize the risk of a bus dragging along a person or object trapped by the doors, an anti-drag system shall be fitted. The anti-drag system shall detect dynamically the force incurred on the door leading edge by dragging a person immediately after the door has closed and continue monitoring once the bus has started driving.
  - When anti-drag is triggered, if the bus is stationary or when driving at speeds less than or equal to [5]km/h the halt brake shall be applied, and an audible and visual alert shall be presented to the driver. The door shall remain in the closed position until commanded to open by the driver.





- When anti-drag is triggered, if the bus is driving at speeds greater than [5]km/h, an audible and visual alert shall be presented to the driver, both alerts maybe generated using the same driver warning devices that are used to alert that the door is in the open position.
- Faults with the object detection or anti-drag system caused by wear or vandalism that impairs detection shall be alerted to the bus driver via the bus computer and a warning.
- Once the bus has reached a speed greater than [15]km/h, the anti-drag system function maybe deactivated until the respective door is next cycled.
- To reduce the risk of tampering of the anti-drag system by passengers the system shall not detect an object of diameter 15mm with a spherical front of R15mm pressed perpendicularly onto the inside surface of the rubber with a force of 150N.
- The anti-drag system shall be able to detect a [0.7]mm flexible strap clamped within the doors over the door height with a maximum 150 N pull out force applied at [30]°, in both forward and reverse driving directions at an ambient temperature of -20°C to +50°C. See Figure 4\_6 below The anti-drag system shall be capable of detection across a range of [10]° to [170]° from the direction of travel, both forward and reverse.

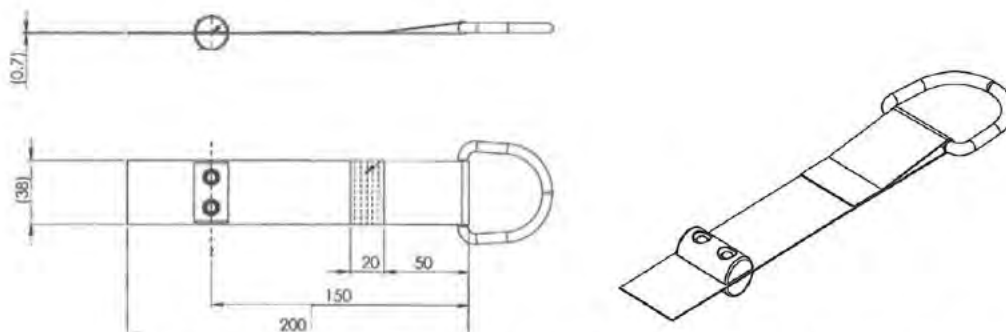

**Figure 4\_6: Anti-Drag system test strap requirements**

- The door opening or closing movement processes shall be completed within a timeframe of between 3 – 4 seconds, this excludes any time delay between door command signal sent and movement commencing.
- An override switch shall be fitted to temporarily deactivate a door related activation of the halt brake in a fault condition. The bus must not be used in passenger service with the override switch activated, the override switch must be positioned so it cannot be unintentionally activated and inaccessible without the use of specialist tools. The switch shall deactivate automatically if the respective door is opened, or the bus ignition is switched off.
- Interior and exterior emergency passenger door controls shall be prevented from unintentional, accidental or misuse in non-emergency situations via suitable positioning, labelling, and fitment of a movable cover/flap. The controls



shall be clearly labelled and confusion with other operational devices shall be avoided by design.

#### **4.5.7.1.2 Door mechanical strength**

- The doors shall withstand the forces that occur when passengers are leaning or falling against the door leaves without causing any non-elastic deformation or loss of operation. A closed and locked door including the glazing shall be able to withstand a 1kN per linear metre over pushing force applied from inside the bus onto the door leaf distributed over 200mm (+/-100mm from door height centre line) across the entire width of the exposed internal surface of the door. It is permissible for some residual deflection after first loading to occur.
- A closed locked door leaf secured and retained by its top and bottom guidance system (including glazing) shall as a minimum, have sufficient strength to withstand without fracture, loss of containment or permanent deflection due to non-elastic deformation, a weight of 68kg impacting at the centre of each door leaf at 2.5m/s.

#### **4.5.7.1.3 Single point failures**

- In the event of a system fault, mechanical failure or door setup being grossly outside of a critical safety tolerance, the door shall be designed in such a way to prohibit normal door operation and notify the driver. Such as the door not moving, jamming on the track, or a sensor detecting the fault.
- The door mechanisms mechanical design and control system logic shall be designed in such a manner that at least two independent faults shall occur at the same time before the respective door is either able to; detach from its fixings leading to potential loss of containment of passengers, risks opening un-commanded, allowing bus movement with the doors not fully closed or unlocked.

#### **4.5.7.2 Other**

- All door header panels must provide adequate prevention against finger ingress to the door operation mechanism.
- Door or door partition handrails positioned to assist boarding and alighting must be fitted at all entrance and exit points and must be shown on the approved arrangement drawings as submitted for TfL review and uploaded to the TfL BVS Database.
- Overhead illumination of door opening area must be provided at minimum levels as stated in section 8.2.

#### **4.5.7.2.4 Maintenance**

- The door system shall be provided with a dedicated maintenance schedule. This shall include details of service hours/days for maintenance trigger points to ensure the system set up remains compliant to manufacturers minimum recommended standards during the recommended maintenance intervals, the following documents shall be provided.



- Daily vehicle check work instruction that includes recommended pre-service checks.
- Periodic maintenance work instruction that includes recommended safety check limits such as the door alignment, interlock setting, lock engagement, door open/close times and fastening security. A record sheet for sign off shall be included (the interval can be longer if the design allows).
- Door system overhaul work instruction and sign off record sheet.
- Minimum acceptable service condition door setting standard, this will consider the acceptable degradation of the door setting wear and tear during the recommended service maintenance intervals.

#### **4.5.7.3 Front doors**

- Front, entrance to be inward glider or outward glider type, flush fitting to the body side when closed and one-piece full depth glass in each door leaf for maximum driver view of kerb side.
- The technical requirement of UNECE R107 Rev 8 Annex 3 section 7.6.5.6.1.1 to 7.6.5.6.1.2 must be met on all doors, including front. The use of soft close edges on front doors is not permitted.

#### **4.5.7.4 Centre and rear doors**

- Centre or rear doors to be outward slider type, flush fitting to the body side when closed and one-piece full depth glass in each door leaf for maximum view of kerb side.
- A delay of 1.5-2 seconds between the driver activating an open or close command and any door movement commencing shall be implemented.
- Door opening and closing audible warning device on all centre and rear doors.
  - To be of beeping sound and not to exceed 75 dBA, when measured at 1m height from the body floor on centre line of the bus and exit door.
  - The audible warning shall activate as soon as a door open or close command is sent and be active for 1.5 – 2 seconds prior to any door movement commencing, the audible warning shall deactivate once the door movement is complete.
- Door opening and closing visual interior warning lamp for passengers shall be fitted in close proximity to the interior door opening aperture.
  - The visual warning beacon shall activate as soon as a door open or close command is sent and be active for 1.5 – 2 seconds prior to any door movement commencing, the beacon shall deactivate once the door movement is complete.
- The door control logic shall be such that it is not possible for the driver to open the exit door while the access ramp is either in the process of extending or retracting. It shall only be possible for the exit door to be opened when the ramp is either fully retracted or fully deployed. However, it must still be possible for an emergency door operation to over-ride the restriction.



## 4.6 Partner Protection

*TfL are currently conducting further research and assessment of data taken from service conditions to develop the requirements, assessment protocols and guidance notes for Partner Protection and ensure their suitability. As such this section provides an understanding of the current expectations, it is however subject to change.*

Bus front ends have been identified as one of the key contact points of the vehicle in collisions with vulnerable road users (VRU). Several different safety features are required to minimise the injury potential in those collisions.

In all assessments of these features, the physical or virtual test vehicle to be assessed shall be configured at its maximum ride attitude from the ground plane, with its mass in running order (the nominal unladen vehicle and driver mass), tyres inflated to manufacturer recommended pressures and vehicle suspension set to normal running conditions (as specified by the OEM for a speed of 25 mph).

### 4.6.1 VRU Frontal Crashworthiness: Minimum Geometry

*This requirement only applies to new vehicles entering the fleet from 2021 as per the Bus Safety Roadmap for new build buses*

All bus front ends are required to have a geometric design that both improves protection for VRUs during the primary impact of a collision and reduces the risks of VRUs being subsequently run over.

All buses shall have a front-end geometry that complies with the minimum bus front end geometry requirements for both vertical rake angle and horizontal curvature.

Vertical rake angle is specified as an angle in the longitudinal plane formed at the intersection of the vertical transverse plane of the vehicle and a plane located at a tangent to the test point surface. The minimum requirements shall be:

- Minimum vertical rake angle of  $[1]^\circ \pm 0.5^\circ$  tested at the worst-case location between vertical heights of  $[0.75]$  m and  $[1.2]$  m from the ground plane and the side reference lines; and
- Minimum vertical rake angle of  $[4]^\circ \pm 0.5^\circ$  tested at the worst-case location between vertical heights of  $[1.2]$  m and 2.0m from the ground plane and the side reference lines.

To ensure only the global geometric features of the bus front end design are tested, the vertical rake angle shall be assessed using a  $236 \pm 5$ mm x  $236 \pm 5$ mm rectangular plane, with its centre placed against the surface of the bus at the test location.

**Where multiple vertical rake angles may be selected at a single test location (e.g. due to the protrusions caused by headlight clusters or bodywork panel joins), then the worst-case vertical rake angle shall be selected.**

Wraparound windscreen and bumper bus front end designs, where the glazed areas and bumper at the front-end edges are curved and the A-pillars are located rearward of the bus front end, are required. The minimum requirements shall be:



- A radius of curvature of at least 150mm tested in the horizontal plane and at the worst-case location between lateral positions of 0mm and 150mm inboard from each side reference line and between vertical heights between [0.75]m and 2.0m from the ground plane.

The side reference line is defined by the geometric trace of the most outboard points of contact between a straight edge 700mm long and the sides of the vehicle, when the straight edge, held parallel to the transverse horizontal plane of the vehicle and inclined rearwards by 75°, is traversed rearwards to contact the sides of the bus front end (Figure 4\_6 and 4\_7).

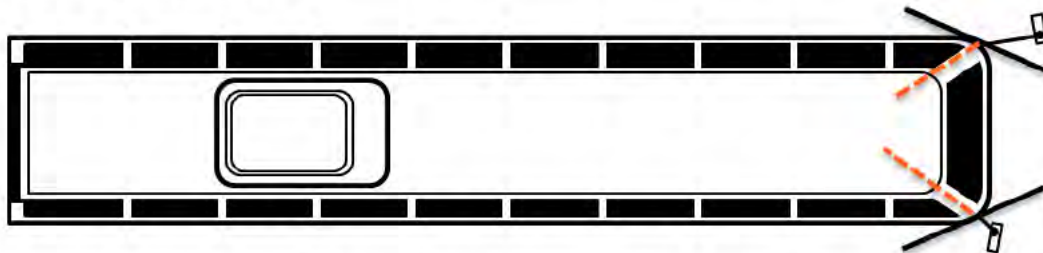

**Figure 4\_6: Side reference line – plan view**

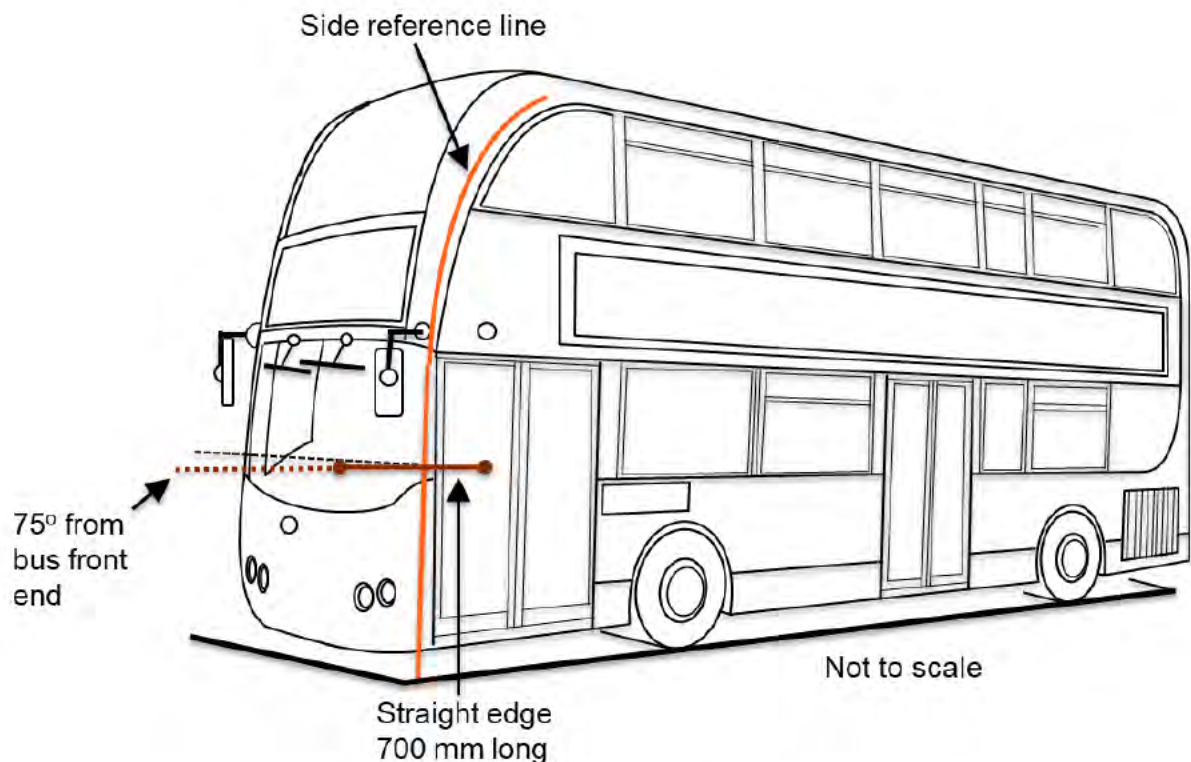

**Figure 4\_7: Side reference line – front/side view**

Compliance may be established through either a CAD based approach or physical testing. The bus OEM shall provide documentary evidence of compliance with these requirements.



#### 4.6.2 VRU Frontal Crashworthiness: Enhanced Geometry

*This requirement only applies to new vehicles entering the fleet from 2024 as per the Bus Safety Roadmap for new build buses*

All buses shall be assessed in accordance with the bus front end geometry test and assessment protocols (Attachment 39), reporting vertical rake and horizontal angles for each test point, bus front end geometry envelope compliance status, the front end geometry score (FEGS), the bus front end geometry star rating and the number of safety performance criteria scores with a value of 0 for each bus model or bus model variant (as appropriate).

All buses shall have a front-end geometry compliant with the bus front end geometry envelope, which is defined by the following boundary conditions:

- Vertical rake angles for all measuring points at all test positions (P1-P5) shall be no less than 4 ° and no greater than 23°.
- Horizontal angles for all measuring points at the outboard test positions (P1 and P5) shall be no less than 20° and no greater than 33°.
- Horizontal angles for all measuring points at the inboard test positions (P2 and P4) shall be no less than 11° and no greater than 18°.

**Where multiple vertical rake angles may be selected at a single test location (e.g. due to the protrusions caused by headlight clusters or bodywork panel joins), then the worst-case vertical rake angle shall be selected.**

All buses shall have a front-end geometry score (FEGS) that exceeds 0%.

All buses shall have no more than eight safety performance criteria scores with a value of 0.

All definitions for above requirements are provided in the bus front end geometry test and assessment protocols (Attachment 39).

The bus OEM shall provide documentary evidence of compliance with these requirements. This evidence may be supported by the submission of the Front-End Geometry Performance Evaluation Tool provided.

Bus models or bus model variants may be exempt from these requirements, should documentary evidence be provided that demonstrates to the Test Service how the geometric design of the bus front end reduces the risks of VRU injuries and run-overs relative to current designs. A simulation-based test and assessment approach may be provided as evidence. Although the OEM has the responsibility to ensure such evidence provides sufficient assurance of real-world improvements in VRU injury and run-over risks, guidelines on a simulation-based testing approach are provided in Annex 1 of Attachment 39.

#### 4.6.3 VRU Frontal Crashworthiness: Energy Absorption

*This requirement only applies to new vehicles entering the fleet from 2024 as per the Bus Safety Roadmap for new build buses*

All bus front ends, in the region of potential head contacts, are required to have a construction that absorbs energy to improve protection for VRUs during a collision and in the event of a contact at that location on the vehicle.



All buses shall have their VRU impact safety performance tested and assessed in accordance with the bus VRU impact test standard, as defined in Attachment 36.

All buses shall have front ends which are energy absorbing or sufficiently compliant and/or frangible to meet the performance requirements of the bus VRU impact test standard.

No bus shall have a head form impact test result leading to a head injury criterion (HIC<sub>15</sub>) value in excess of [1700].

All buses shall meet the minimum bus VRU impact test performance score (BITS) requirement of [70]%.

#### 4.6.4 **VRU Frontal Crashworthiness: Wiper Protection**

*This requirement only applies to new vehicles entering the fleet from 2021 as per the Bus Safety Roadmap for new build buses*

Windscreen wipers, and in particular the windscreen wiper bosses and spindles, that are mounted in the region of a potential VRU impact provide rigid structures that may cause greater injuries if struck. Windscreen wipers are therefore required to be positioned above the windscreen or have a construction that absorbs energy to improve protection for VRUs during an impact.

All buses shall have the impact safety performance of their windscreen wipers tested and assessed at their worst case location in accordance with the bus VRU impact test standard as defined in attachment 36.

Windscreen wipers mounted at a height of greater than 2.0 m from the ground plane shall be exempt from this requirement.

No existing model bus shall have a wiper spigot:

- Lower than 2.0 m from the ground, and
- Without a protective covering that provides a minimum reduction in head injury criterion (HIC<sub>15</sub>) value of 50 % during a headform impact test.

No new bus shall have a windscreen wiper spigot:

- Lower than 2.0 m from the ground plane,  
OR
- With a headform impact test result leading to a head injury criterion (HIC<sub>15</sub>) value in excess of [1700].

Wipers are exempt from calculations of vehicle length. However any additional protection around low mounted wipers shall be included in the vehicle length.

Any proposed design solution must be agreed with the relevant Approval Authority withing TfL prior to implementation.



#### 4.6.5 **VRU Frontal Crashworthiness: Mirror replacement Class II CMS**

*This requirement only applies to new vehicles entering the fleet from 2021 as per the Bus Safety Roadmap for new build buses*

In order to avoid situations where mirrors and mirror arms collide with vulnerable road users, all buses shall be fitted with a class II CMS to replace the main mirror. These devices shall be as specified by section 4.3.4.4.

### 4.7 **Miscellaneous Safety features**

All wheel arches shall be fitted with tyre blow out protection liners

Headroom should be sufficient at all positions throughout the bus without the need to provide impact protection or warning notices.

In addition to emergency controls on main entrance and exit doors, exits may be provided via main saloon windows or a suitably positioned exit door. These window positions or door must be shown on the general arrangement drawing as approved by TfL and uploaded to the TfL BVS Database..

Double-deck buses shall be fitted with a substantial near side front tree guard, located into the structure of the bus, giving additional forward protection to the front seated passengers, exterior dome and near side corner window-pillar.

#### 4.7.1 **Rescue Sheet (RS) & Emergency Rescue Guide (ERG)**

To provide information to emergency services, TfL require a Rescue Sheet (RS) and Emergency Rescue Guide (ERG) to be custom generated for each specific make and model of bus design by the Bus Manufacturer. The RS and ERG are two separate documents, based on the ISO 17840-2 and ISO 17840-3.

Every bus operating on the TfL network shall provide a model specific RS & ERG, which is to be made available to Fire and Rescue services.

A digital version of each RS & ERG shall be provided to TfL, London Fire Brigade (LFB), and to the company which manages the Fire and Rescue RS & ERG database. TfL will assist with the liaison between the LFB and Fire Service database maintainer.

##### 4.7.1.1 **Rescue Sheet (RS)**

The purpose of the RS is to use as little text as possible, it is 'quick information' for first responders.

When creating an RS, the following specification shall be followed:

- The structure of the template must follow ISO 17840-2:2019
- All pictograms used must be taken from ISO 17840-2:2019.
  - Any other pictograms shall be deemed non-compliant.
- Ensure the quality of the picture / drawings / photos / pictograms follow the General Recommendations in ISO 3864-1.
  - This is to make certain that the document is easily read and understood.
- Ensure the quality of the picture / drawings / photos / pictograms is a minimum of 300 DPI, as per ISO 17840-3:2019.
  - Therefore: do not copy and paste pictograms from other documents





- The RS must not exceed 5 pages.
- Before any RS is put into service it must be verified by TfL.
- A full user guide with examples can be provided by TfL to assist in the creation of a RS.
- A digital copy of the Rescue Sheet shall be provided to TfL, LFB, and to the Fire and Rescue service RS & ERG database maintainer.

An example of an RS is [located on the TfL BVS Data Base HERE](#).

#### **4.7.1.2 Emergency Rescue Guide (ERG)**

When creating the ERG, the following specification should be followed:

- The structure of the template must follow ISO 17840-3:2019.
- All pictograms used must be taken from ISO 17840-3:2019
- Minimum recommended resolution of images should be 300 DPI.
  - Any distracting information on images should be removed (e.g., faces, people).
- Before an ERG is put into service it must be verified by TfL.
- A digital copy of the ERG shall be provided to TfL, LFB, and to the Fire and Rescue service RS & ERG database maintainer.
- There is no page limit for the ERG.
- A full user guide with examples can be provided by TfL to assist in the creation of an ERG.

An example off an ERG is stored in the [supporting documents location of the BVS Database HERE](#)

## **5 Environmental Performance**

### **5.1 General**

The combined engine and transmission acceleration controls should limit the bus to a rate that delivers an acceptable LBSL emissions performance whilst still providing the driver with adequate acceleration performance in the fully laden condition.

Full bodywork insulation shall be fitted to sides, roof, front and rear and internal bulkheads where appropriate to minimise heat loss from the heated passenger saloon to the environment in cold weather and to minimise heat intrusion from the engine into the passenger saloon, particularly in warmer conditions.

### **5.2 Air quality and emissions**

The tailpipe emissions from the bus shall be measured according to the process defined in Attachment 1 and shall fall within the limit values specified in that Attachment.

Bus production lead times to certification shall be minimised at times of Euro legislation updates, providing the earliest introduction of latest emissions legislation. No advanced registration of earlier Euro status engines will be accepted.



The use of BS EN 590:2000 (50 ppm sulphur) compliant diesel fuel is a minimum requirement. Fuel utilised may also be subject to verification by a LBSL testing procedure.

Any alternative fuels, additives, after treatments, power sources or technology that may potentially change the agreed emissions standards will require the prior consent of LBSL before their use in LBSL's contracted bus fleet. OEM / Supplier funded testing over the LBC cycle under LBSL supervision is required to establish that the technology proposed delivers emissions standards that are better than the equivalent currently used standard bus.

Exhaust fumes should be delivered on or below the bus skirt to the rear of the bus, either at the offside portion of the rear of the bus, or on the offside of the bus, behind the rear axle. Exhaust fumes shall not be emitted at the near side of the bus. If any exhaust fumes are not delivered on or below bus skirt level, they should be delivered at roof level with the final position agreed with LBSL prior to bus manufacture / design.

To prevent buses running engines or over using high voltage systems (in the case of Zero Emission Vehicles) and ancillary systems for long periods whilst stationary, an automatic ignition shutdown system shall be incorporated.

The engine or high voltage systems (in the case of Zero Emission Vehicles) and any noise generating ancillary systems shall be automatically shut down when the following 2 conditions are met:

- The bus has been stationary for 2.5 minutes

AND

- The park brake is applied.

The driver shall be provided with:

- An audible warning 1 minute prior to the shut down

AND

- Have the facility to override this back to the 2.5 minutes of stationary operation

All buses shall have this idle shutdown operation, regardless of powertrain type.

### **5.3 Carbon Dioxide Emissions**

The bus OEM shall, for buse types, provide a statement of the embedded carbon footprint of the bus covering initial manufacturing to disposal at the end of a 14 year life cycle. This calculation shall exclude consumables used during operations.

Hydraulically driven cooling fans, for any system, shall not be permitted.

### **5.4 Noise emissions**

The braking system should use disc brakes at each wheel station in order to minimise brake squeal.

The exterior and interior noise level of the bus shall be tested and assessed using the method defined in Attachment 2. The complete vehicle supplied for testing either by the OEM or an operator shall be fully compliant with all other aspects of this specification and be fitted with all equipment necessary for operation in London.



The results of the test shall demonstrate that the drive-by noise test emissions are at least 1 dB less than the legal limit (diesel buses) or 2 dB less than the legal limit (hybrid buses) defined in type approval regulation. Zero Emission Buses shall be at least 3 dB less than the legal limit

All noise test results may be subject to LBSL verification at any time.

The OEM shall demonstrate compliance with this requirement by providing a copy of both the type approval certificates relating to the noise tests and a LBSL type approved noise statement, as set out in Attachment 2.

## **5.5 Infrastructure protection**

Buses shall be equipped with road friendly suspension, which is defined as a suspension system where at least 75 % of the spring effect is caused by an air spring or where the suspension is recognised as equivalent to air suspension using the definitions of Annex II of Council Directive 96/53/EC on authorised weights and dimensions.

## **6 Operational Efficiency**

Buses shall be capable of high frequency, stop-start, fully passenger laden Public Service Vehicle (PSV) operational schedules, operating in adverse traffic conditions, during typical London weather conditions. The typical operational parameters are 18 hours per day, 7 days per week, 364 days per year, with an average operational speed of between 6 and 12 mile/h, and a minimum average daily range of 150 miles without the need to refuel the bus.

The bus proposed must be suitable to achieve a minimum efficient operational life within London of 14 years.

### **6.1 Vehicle capacity**

OEMs must have general dimensions, seating and layout arrangement drawings agreed by LBSL as approved by TfL and uploaded to the TfL BVS Database. These individual manufacturers' drawings should comply with the detail below. They are deemed to be approved by LBSL if marked with a valid a LBSL reference number issued from the Nominated Officer. The respective OEM's LBSL reference number must be quoted on all proposals. If a OEM cannot provide the approved LBSL reference number, a fully dimensioned general arrangement drawing for the proposed bus must be provided by operators submitting a bid based on the use of that vehicle. LBSL reserves the right to not consider bids unless this condition can be satisfied.

Any amendments to any of these layout drawings will require the approval of LBSL before a bus constructed with the revised layout can be used in service in London.

A laden and kerb / un-laden weight chart by axle and total against GVW shall be provided for the completed bus Body Layout Option. This must be approved by LBSL. Any significant changes to this standard must be notified to LBSL.

Unladen weight has a relationship to fuel economy and buses should be designed to maximise their fuel economy.



The standing capacity of the bus will be determined by the lower of the calculation by weight (using 68 kg per person) and no more than 6 standees per square meter in the areas of the bus where standing is permitted.

All buses should comply with the general dimensions and capacities defined in Table 1 and a layout drawing identifying the actual dimensions and capacities for the bus shall be provided to LBSL. Any configurations that do not fit the table should be discussed with TfL.

The wing mirrors are not included in either the width or length of the bus.



**Table 1: General Dimensions and Capacities**

| Passenger capacity (minimum)                                   |        | Single deck<br>Single door<br>36 |       | Single deck<br>Single door<br>45 |       | Single deck<br>Dual door<br>50 |       | Single deck<br>Dual door<br>55 |       | Single deck<br>Dual door<br>60 |       | Single deck<br>Dual door<br>70 |       | Double deck<br>Dual door<br>87 |       |
|--|--------|----------------------------------|-------|----------------------------------|-------|--------------------------------|-------|--------------------------------|-------|--------------------------------|-------|--------------------------------|-------|--------------------------------|-------|
|  |        | Min                              | Max   | Min                              | Max   | Min                            | Max   | Min                            | Max   | Min                            | Max   | Min                            | Max   | Min                            | Max   |
| Overall Length*  | metres | 7.8                              | 7.9*  | 8.9                              | 9.0*  | 9.3                            | 9.9*  | 10.1                           | 10.4* | 10.4                           | 10.9* | 11.5                           | 12.0* | 10.1                           | 10.9* |
| Overall Width*   | metres | 2.30                             | 2.55* | 2.45                             | 2.55* | 2.45                           | 2.55* | 2.45                           | 2.55* | 2.45                           | 2.55* | 2.45                           | 2.55* | 2.45                           | 2.55* |
| Overall Height (non- Zero Emission)*                           | metres | 2.85                             | 3.10* | 2.85                             | 3.10* | 2.85                           | 3.10* | 2.85                           | 3.10* | 2.85                           | 3.10* | 2.85                           | 3.10* | 4.20                           | 4.42* |
| Overall Height (Zero Emission only)*                           | metres | 2.85                             | 3.40* | 2.85                             | 3.40* | 2.85                           | 3.40* | 2.85                           | 3.40* | 2.85                           | 3.40* | 2.85                           | 3.40* | 4.20                           | 4.42* |
| Aisle headroom at centre line                                  | metres | 1.83                             |       | 1.83                             |       | 1.83                           |       | 1.83                           |       | 1.83                           |       | 1.83                           |       | 1.83                           |       |
| Seat Width   | mm     | 440                              |       | 440                              |       | 440                            |       | 440                            |       | 440                            |       | 440                            |       | 440                            |       |
| Aisle Width (between seats) - top of seat back                 | mm     | 590                              |       | 590                              |       | 590                            |       | 590                            |       | 590                            |       | 590                            |       | 590                            |       |
| Aisle Width (between seats) - bottom of seat back              | mm     | 535                              |       | 535                              |       | 535                            |       | 535                            |       | 535                            |       | 535                            |       | 535                            |       |
| Objective Wheelchair space **                                  | metres | 2.0                              |       | 2.0                              |       | 2.0                            |       | 2.0                            |       | 2.0                            |       | 2.0                            |       | 2.0                            |       |
| Entrance & Exit step Height (Un-knelt)                         | mm     |                                  | 320   |                                  | 320   |                                | 320   |                                | 320   |                                | 320   |                                | 320   |                                | 320   |
| Entrance & Exit step Height (knelt)                            | mm     | 265                              | 240   | 265                              | 240   | 265                            | 240   | 265                            | 240   | 265                            | 240   | 265                            | 240   | 265                            | 240   |
| Entrance & Exit Door Headroom                                  | mm     | 1840                             |       | 1840                             |       | 1840                           |       | 1840                           |       | 1840                           |       | 1840                           |       |                                |       |
| Entrance Door Clear Width***                                   | mm     | 1200                             |       | 1200                             |       | 1200                           |       | 1200                           |       | 1200                           |       | 1200                           |       | 1200                           |       |
| Exit door Clear Width***                                       | mm     | n/a                              |       | n/a                              |       | 1200                           |       | 1200                           |       | 1200                           |       | 1200                           |       | 1200                           |       |
| Passenger capacity:-   |        |                                  |       |                                  |       |                                |       |                                |       |                                |       |                                |       |                                |       |
| Total  |        | 36                               |       | 45                               |       | 50                             |       | 55                             |       | 60                             |       | 70                             |       | 87                             |       |
| Low Floor Seated: Priority                                     |        | 4                                |       | 4                                |       | 4                              |       | 4                              |       | 4                              |       | 4                              |       | 4                              |       |
| Low Floor Seated: Preferential (in addition to Priority)       |        | 2                                | 4     | 2                                | 4     | 2                              | 4     | 2                              | 4     | 2                              | 4     | 4                              |       | 4                              |       |
| Total Seated Lower Deck  |        | 18                               |       | 24                               |       | 24                             |       | 26                             |       | 30                             |       | 35                             |       | 21                             |       |
| Total Seated Upper Deck  |        | n/a                              |       | n/a                              |       | n/a                            |       | n/a                            |       | n/a                            |       | n/a                            |       | 41                             |       |
| Total Standing (assuming <6 people/sqm of standee floor space) |        | 15                               |       | 20                               |       | 24                             |       | 26                             |       | 28                             |       | 32                             |       | 22                             |       |
| Wheelchair   |        | 1                                |       | 1                                |       | 1                              |       | 1                              |       | 1                              |       | 1                              |       | 1                              |       |
| Standing with wheelchair                                       |        | 11                               |       | 18                               |       | 20                             |       | 22                             |       | 24                             |       | 28                             |       | 18                             |       |

\*= Subject to being able to traverse the specified route and serve all stops safely

\*\*= target - subject to a agreement on total capacity and seating a minor reduction may be permitted

\*\*\*= Refer to Section 6.3 for further details

## 6.2 Energy efficiency – Electric Vehicles

OEMs and Operators need to be satisfied that the battery capacity, charging regime and battery life of vehicles are suitable and appropriate for the route(s) on which they are proposed, including the heating and cooling requirements set out in this specification.

### 6.2.1 Minimum Charging Requirements

Each bus must be capable of DC charging via a CCS combo-2 socket. Other type connections can be installed as an option.

### 6.2.2 Opportunity Charging

Where a bus is fitted with an Opportunity Charging system, it shall comply with the design and operation requirements detailed in the [OPPCharge Specification – 2<sup>nd</sup> Edition 20190421](#)

The latest version of which is available for download from [oppcharge.org](http://oppcharge.org)

#### 6.2.2.1 Performance Tracking

The following parameters shall also be logged and made available to TfL in order to monitor vehicle and system performance in use (required units in brackets):

- Vehicle Energy Consumption (kWh/km)
- Charge time (minutes)
- Charge Energy Transfer (kWh)
- Charge Power Transfer (kW)
- Charge Efficiency (%)
- Vehicle Total Battery State of Charge – Pre-Charge (%)
- Vehicle Total Battery State of Charge – Post-Charge (%)

## 6.3 Minimising dwell time

The choice of the number of doors fitted to a bus shall be informed by an analysis of the effect of dwell time at typical bus stops on the route intended for.

London Buses generally operate a two door system with the entrance door forward of the front axle and the exit door between front and rear axle. When single or three door buses are requested, the front door remains unchanged, the centre door is deleted or duplicated at a specified area of the bus.

Requirement for all service doorways are as follows:

Entrance and exit doors shall provide a minimum individual clear width of 1200 mm, utilising an equal width two door leaf closure. A reduction in the clear width is permitted as defined within UNECE Regulation 107 as amended. Where a reduction is required, the minimum individual clear width of 1030 mm must be maintained across the entire height of the door.

## 6.4 Fleet management

### 6.4.1 CCTV/Audio recording

Colour Digital CCTV shall be fitted to all buses and shall provide the specific functionality defined in Attachment 11.

Evidence shall be supplied to demonstrate that

- recording systems fully comply, at all times, with the relevant principles of the General Data Protection Regulations (GDPR)
- operators have registered for this type of application with the Information Commissioner's Office
- Privacy Impact Assessment (PIA) has been completed and signed
- PIAs will be reviewed periodically to ensure measures continue to remain proportionate and/or necessary.
- A full detailed privacy notice has been placed on your company website, with the website information included in the space on the sign.

Recording equipment will be subject to periodic auditing for installation compliance and serviceability.

Where audio recording (which is optional) is installed, these requirements apply to both continuous and driver activated recording devices, (eg Incident Data Recorders). Close proximity (directional) microphones must be used to ensure only conversations in the immediate area around the driver cab can be heard. Signage informing passengers that audio recording is operating in the driver's cab area shall be installed. This will be issued by LBSL.

### 6.4.2 Fleet Management System

All buses shall be fitted with Fleet Management System version 3, unless specifically exempt as agreed with LBSL.

The Fleet Management System should be compliant with the requirements set out in Attachment 3.

All buses shall be provided with ducting and cable runs to ease the installation of additional equipment. These shall meet the requirements defined in Attachment 4.

### 6.4.3 Communications

LBSL will issue, free of charge, iBus equipment to operator or OEM against each set of new vehicles confirmed by LBSL

All buses must make provision for the installation and suitable protection of this equipment. The approved package of installation must consider the free issue iBus equipment as an integral part of the design of the vehicle.

For full details of the installation principles recommended, refer to the generic 'iBus Installation Manual' [Document Ref: LBSL Equipment for new buses Installation

# London Buses

New Bus Specification Version 2.5

manual BHN01 170970V15] which has been issued to all bus OEMs. A copy of the 'iBus Installation Manual' is available on the Hyperion server to all bus operators.

For any new bus types or modifications to the roof area of existing designs, the position of the antenna must be approved by LBSL Drawings showing the roof layout and positions/ dimensions of all roof mounted equipment must be submitted as part of the general arrangement drawing.

The bus communications antenna should always be positioned on the highest point of the roof and spaced well away from any other objects or obstructions.

In order to maintain the omnidirectional radiation pattern of the antenna and to avoid the shielding of radio signals in certain directions, a minimum spacing between the antenna and any other object that protrudes above its mounting point must be observed:

- Objects up to 300 mm in height above the antenna mounting point must be spaced at least 1000 mm away from the antenna.
- For objects that are between 300 mm and 500 mm in height, the minimum spacing must be increased to 2000 mm.
- If the item height exceeds 500 mm, please contact LBSL's Radio Infrastructure Engineer.

No electronic equipment may be located in the roof space directly underneath or within 500 mm of any part of the bus antenna. Any cables routed within this zone must be fully screened and bonded to the vehicle earth at both ends.

## 6.4.4 Ticketing

LBSL will issue, free of charge, a ticketing machine, base plate and smart card readers to operator or OEM against each tender award. A coin tray is not required.

All buses shall make provision for the installation and suitable protection of this equipment. The approved package of installation shall consider this ticketing equipment as an integral part of the design of the vehicle.

For full details, refer to the installation and provision of electrical supply to the Ticket Machine as described in the document "Guidelines for Bus Builders for the installation of Ticket Machines with Smart Card Readers", published by the ticketing system supplier and available from LBSL.

Note: The ticket machine and equipment will be installed after a bus arrives in London.

By preference, the card validator should be separated from the main Electronic Ticket Machine (ETM) and located outside the driver's cab to permit a straight forward cab seal and allow best ergonomic access for passengers to present their card.

The passengers should face the driver when validating.

Passengers shall be able to easily see the ETM screen (for error messages, current balance, etc).

The Smart Card Reader shall not be located rearward of an angle of [70°] from the centreline of the bus from the driver's seating reference point.



# London Buses

New Bus Specification Version 2.5

Access shall be provided to allow the Smart Card Reader and ETM to be removed with minimal effort.

By preference, the main body of the ETM should not protrude through the assault screen. The Smart Card Reader may protrude if sealed effectively. See Figure for best practice example.



**Figure 6\_1: Smart Card Reader ONLY protrudes through the assault screen**

Note: this material must also comply with assault screen materials requirements regarding vision and impermeability to air.

In some cases, the assault screen might seal over the ETM and the Smart Card Reader, separating the Passenger from Smart Card Reader. In these cases, the Smart Card Reader should be ergonomically accessible and the distance between the Smart Card Reader and the seal material shall be no more than 10 mm at the furthest point to provide a consistent accuracy of card reading. See Figure 6\_2 for a best practice example.



**Figure 6\_2: Flexible plastic over the top of Smart Card Reader pad. Held in place by a removable polycarbonate panel**

Access to paper printed tickets (including paper roll change) is not required.

The ticket machine base position shall be provided with a clean power supply that is maintained for 30 minutes after shutdown.

## 7 Accessibility

The completed bus must be designed as a low floor.

### 7.1 Seating

#### 7.1.1 Priority and Preferential Seating

A minimum of 4 priority seats shall be provided and must be clearly identified by the standard (LBSL Issue) notice.

A minimum of a further 2 additional “preferential” passenger seats shall be provided in the low floor area (see table 6-1), for passengers who are less able to stand or who are travelling with small children.

**Preferential Seats are defined as being of similar space requirement to the priority seats and as a minimum requiring step free access.**

Preferential seats must be clearly identified by the standard (LBSL Issue) notice (please see section 10.3 of this document for further information about Internal Signs and Notices).

Priority or preferential seating on the low floor area shall maximise under-seat space as much as possible, for use by guide or assistance dogs. The height from the floor to the top of the seat cushion should be approximately 490 mm to achieve this

All of these seats will be fully defined on the approved seating layout as approved by TfL and uploaded to the TfL BVS Database.

#### 7.1.2 Seating Demarcation

For Moquette fabrics:

- Both the standard and priority seats must use the same pattern design.
- The priority moquette must use a different colorway to achieve a consistent demarcation with the standard moquette.
- Moquette's colourway must use mid/dark tone colours which respond well to wear and tear over time.
- Designs should be considered in the context of other colours used on the vehicle
- Woven moquettes must incorporate a proportion of uncut looped weave as well as cut weave which physically breaks up the surface to improve wear and tear.
- Both the standard and priority designs are required to contrast against the hand poles. Light Reflectance Value (LRV) of the handpole's colour must be considered as the reference value against all moquette colourways.

# London Buses

New Bus Specification Version 2.5

- The compliant contrast value of the moquette must be 30 points different against the handpole's LRV number according to Figure 7\_2, below.
- The priority seat must include a badge with the wording 'This is a priority seat' as defined in Figure 7\_1, below.
- Priority badge contrasting colours must be contained within the moquette colourway, alternatively, infill colour must be Pantone 2935 C, as in Figure 7\_1, below.

For other materials, e.g leather:

- The principles above shall apply

All proposed changes to the interior must have prior written approval from The Nominated Officer Tom Cunnington, Head of Buses Business Development ([Tom.Cunnington@tfl.gov.uk](mailto:Tom.Cunnington@tfl.gov.uk)).

Help with compliance can be provided by the design team at Transport for London [corporatedesign@tfl.gov.uk](mailto:corporatedesign@tfl.gov.uk)

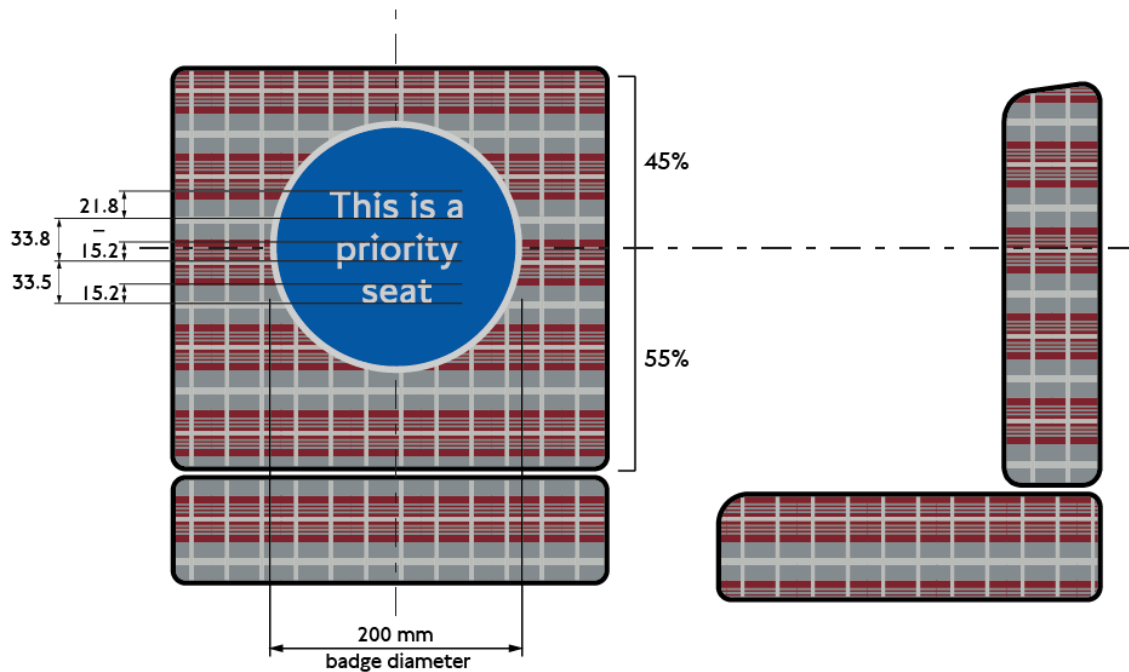

**Figure 7\_1: Size and position of the priority seat badge on the bus's priority seats**

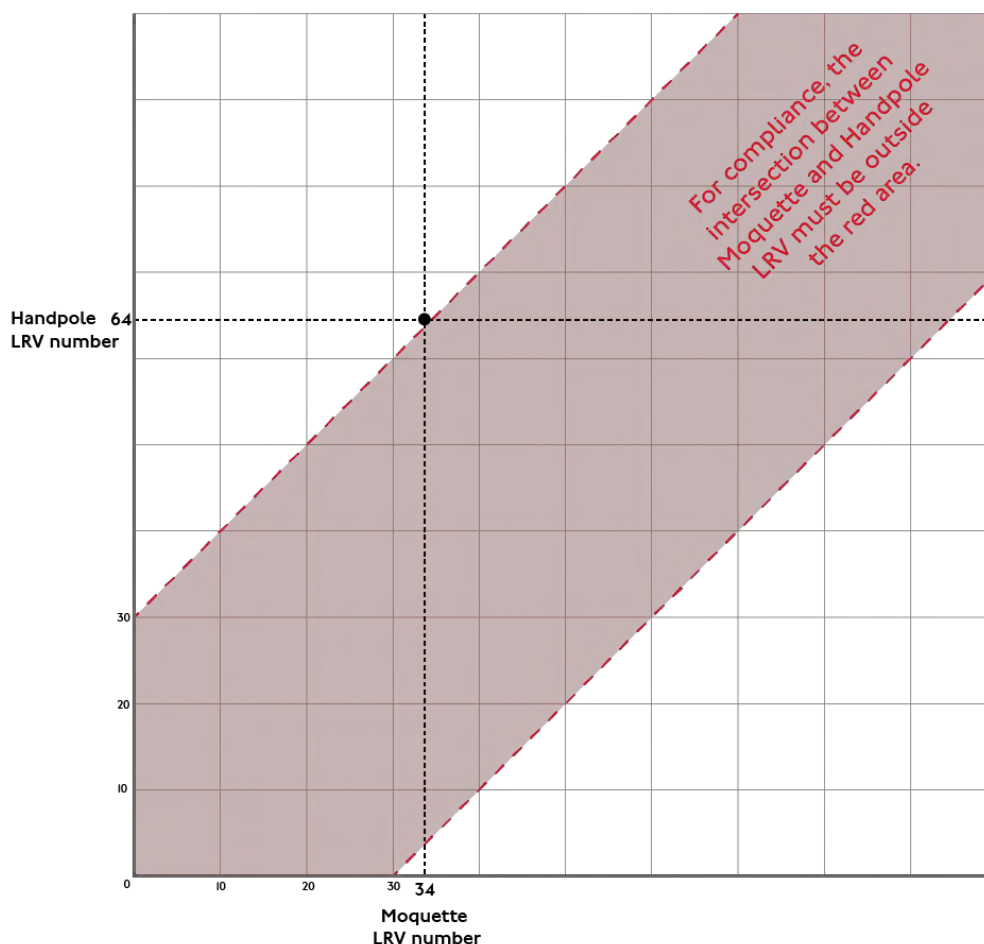

**Figure 7\_2: Graph defining BS 8300 compliant level of contrast between two adjacent surfaces. For example, if a handpole has an LRV of 64 points, then a compliant moquette should not exceed 34 LRV points**

## 7.2 Ramps

### 7.2.1 General Ramp Requirements

An access ramp shall be provided to enable wheelchairs to ride across the gap between kerb and vehicle. Access ramps shall:

- Be power operated by driver controls;
- Telescopic single or two stage ramp platform type with minimal deviations in surface plane;
- Have a total platform length of no less than 1000 mm when fully deployed. This length must not include any section of the floor;
- Not incorporate a hinged lowering floor section or any similar design arrangement intersecting with the top of the ramp platform;
- Incorporate exterior ramp request buttons adjacent to the wheelchair entrance / exit door. These must be positioned clear of the open door position;
- Be installed in a way that maximises protection of the ramp from damage and operational reliability;

# London Buses

New Bus Specification Version 2.5

- Incorporate an audible warning of ramp deployment. The warning shall be of beeping sound and shall not exceed 75 dB(A), when measured at 1.25 m height from the exterior ground, on the centre line of the exit door at a distance of 1.5 m.
- Automatically undertake a partial operation extending cycle of approximately 50 mm deployment on every start-up of the bus. This is to test the ramp and remove any loose dirt or debris from ramp mechanisms. The ramp deployment audible warning device must not sound during this test operation.
- Display a constant warning light in the driver's cab if operation of the ramp fails in service. This shall remain illuminated whenever the bus is in use, until a successful ramp operation occurs.
- Be positioned such that the ramp forward edge is recessed at the centre door from the main bodywork exterior by not less than 25 mm and ideally by 35 mm. The area between the lower edge of the closed door leaf and the floor should be protected against water or any other form of material ingress.
- Function on all kerb surfaces likely to be encountered on London streets.

## 7.2.2 Ramp Edge Protection Requirements

All ramps shall have edge protection to ensure wheelchair users can use the ramp in a safe manner. Ramp edge protection shall meet the following requirements:

- The fixed structure shall cover the outer edges of the board(s) surface parallel to the direction of mobility device travel, and shall have the following design features incorporated:-
  - i. The structure shall be a minimum height of at least 25mm measured vertically from the board surface
  - ii. A section of not less than 50mm in length from the ramp forward edge intersecting with the kerb shall have no edge protection structure present to allow a mobility device to access the ramp board at corners without any obstruction
  - iii. The structure forward section shall be a tapered profile of not more than 50mm in length from the board surface, rising to the structure's maximum height
- The structure shall have no sharp edges or other protrusions that may cause injury and/or damage to mobility device equipment. As a minimum the corners of the structure shall be rounded to a radius of not less than 5mm, and edges rounded to a radius of not less than 2.5mm
- Full consideration shall be given to ensure adequate levels of protection/enclosures around sliding mating surfaces
- The structure shall have the same solid contrasting yellow colour to that of the board edge band
- Full consideration shall be given to ensure the material and/or design used, while being durable with no distortion and/or flexing under normal conditions, does not significantly increase overall weight of ramp

# London Buses

New Bus Specification Version 2.5

- The ramp operating systems and whole assembly shall be designed for cost effective full life operation and maintenance
- Have a safe working load of not less than 350kg
- The fixed structure shall not contradict/contravene any and all other minimum requirements as defined in PSVAR2000 and UNECE Regulation 107 as amended

## 7.2.3 Additional notes to manufacturers/suppliers

The performance/design requirements above set out minimum standards. TfL will welcome discussions on other innovative system designs that exceed and/or fall outside of this preferred design option.

The fixed structure is the preferred option in order to design out additional complex moving/mechanical systems required to deploy/retract structure. This is to remove complexity, maintain durability under all operating conditions, remove increased maintenance cost, and reduce risk of failure.

The ramp with fixed structures shall be approved either through whole vehicle type approval certification and/or independent certification through an approved certification authority.

## 7.3 Wheelchairs

All buses must make provision to carry a wheelchair and its occupant. Buses shall be designed such that wheelchair access is via the door positioned mid wheelbase on two or more door buses or via the front door on single door buses.

### 7.3.1 Wheelchair Area Dimensions and Appearance

Objective wheelchair area length shall be  $\geq 2000$  mm unless agreed otherwise by the Nominated Officer. The wheelchair area shall be located on the off side:

- Opposite the wheelchair entrance / exit door (two or more door buses.)
- Immediately rearward of the driver's cab and wheel box (where appropriate) (Single door buses).

The wheelchair interior manoeuvring area and the ramp deployment area must be monitored by CCTV and displayed on the driver's cab monitor when doors are open.

The wheelchair area shall provide alternative buggy space and standing area when not in use by a wheelchair user. Suitable hand rails and leaning rails must be provided for this purpose.

A wheelchair logo shall be incorporated into the floor covering, readable by a person facing the off side of the vehicle. The logo shall display the rearward facing position of the wheelchair. The full wheelchair area shall be coloured blue (as close as possible to the blue used on the wheelchair notice, PMS 300) and the wheelchair logo shall be coloured white. The wheelchair logo must comply in size and appearance to that shown in Attachment 7. The designated wheelchair area must be shown on the respective OEM's bus layout drawings as approved by TfL and uploaded to the TfL BVS Database.

# London Buses

New Bus Specification Version 2.5

The main floor covering surrounding the wheelchair area may be coloured at the discretion of the operator but must offer substantial colour contrast compared with the full wheelchair area.

## 7.3.2 Wheelchair Area Handrails and Bell Pushes

The wheelchair floor to ceiling security handrail must have two bell pushes. The lower (blue button, facing forwards) to activate ramp request (as required by PSVAR2000) and a higher (red button, facing rearwards) as a standard bell push.

The wheelchair stanchion hand pole should not attach to the floor to allow for unhindered manoeuvres into and out of the wheelchair area.

The ramp request blue button push operation must activate an alternative sound from that of the standard bell push. The alternative sound must be:

- audible each time the button is pressed
- clearly audible from the wheelchair position
- easily accessible by the wheelchair occupant while in the recommended travelling position.

The blue ramp request button when pressed must:

- illuminate a ramp request light in the driver’s cab
- be clearly visible
- remain illuminated until the wheelchair exit door is opened

A manual or automatic security arm shall not be used to replace the floor to ceiling handrail.

*Note: Special attention to the design and positioning of the vertical stanchion pole around the wheelchair area is required to ensure the wheelchair manoeuvrability space is optimised for access and egress. A fixed anti-slew wheelchair restraint design arrangement to the aisle side of the wheelchair area that avoids the stanchion being fixed to the floor would be a preferred option. In addition, special attention must also be given to ensuring the blue access ramp request button is easily reached by the wheelchair occupant travelling in the recommended rear facing position.*

## 7.4 Bell Pushes and Handpoles

Stanchion pole design/arrangements must be such that standing passengers are not able to support themselves in the seating position.

All bell pushes are required to be marked in brail with the brail symbol for the letter S, as shown in Figure 7\_1, and the word ‘STOP’ in white. This is to provide additional assistance to the iBus audible information announcements.

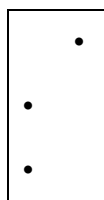

**Figure 7\_1: Brail symbol for S**

# London Buses

New Bus Specification Version 2.5

Bell pushes at priority seating areas must be positioned such that they are within easy reach, and passengers can remain seated while operating them.

In addition to the requirements detailed in PSVAR2000 (where bell pushes are referred to as 'communication devices' and specifically "*2(a) a communication device shall be operable by the palm of the hand*"), all bell pushes shall be designed such that the button portion of the bell push sits proud of the surround.

- The bell push functionality shall be designed such that no part of the button is required to sit recessed to the bell push surround during passenger use.

## 7.5 Induction Loops

### 7.5.1 Induction Loop Zones

Buses shall be fitted with an induction loop system linked to iBus announcements, and for driver-passenger communication with T band electronic hearing device(s). The following areas must be covered by induction loop(s):

- Passenger entrance platform / cab interface
- Priority seating positions
- Wheelchair area

The induction loop zones must provide sufficient audio frequency levels to ensure passengers using T band electronic devices can comfortably hear the driver and iBus announcements when positioned in each of the above areas.

Each bus type will have unique differences depending on seating layout, single/double deck, loop pad size, panel design, and available space behind panelling. The induction loop installation standards should take all of the design features into account to ensure the system functions are at the optimised operating range, providing the best possible service to customers.

A driver's cab microphone, for communicating with passengers using T band equipment must be:

- Active at all times when the bus is in service.
- Positioned to the side or above the driver partition screen.

Nationally accepted signage/notices shall be attached at each location identifying induction loop zones.

### 7.5.2 Induction Loop Documentation and Testing

The induction loop supplier and OEM must provide to LBSL a specification document for each bus type showing:-

- Exact pad location using visible datum points and measurements for loop positioning
- Audio frequency field strength using diagrams showing coverage along swept area, horizontal and vertical axis
- Background noise, interference does not exceed any of the recommended limits as defined in IEC TR 60379:2017+A2:2020 as well as the standards



referenced within it (IEC 60118-4:2018, IEC 60268-16, IEC 62489-1 and IEC 62489-2) :

To ensure consistency in testing methods and standards; the height measurements within the swept area must be specified to ensure all passenger groups including seated, wheelchair users and standing passengers have a clean audio signal free from interference.

Only testing and measuring equipment approved by the induction loop supplier must be used.

## 8 Occupant Experience

### 8.1 Driver cab ergonomics

The general layout shall be suitable as a working environment and be ergonomically designed to assist and protect the driver.

The windscreen in front of the driver shall have a tinted section at the top or a suitable sunblind

A driver operated PA system (for driver to passenger communications) will be provided as part of the iBus system.

The cab area must be designed to accommodate the iBus system as described in section 4.3.2, 4.9 and 4.10 of the generic iBus installation manual (BHN01 1709 70V15) with details of the optimal and acceptable zones recommended for placement in the cab of the driver's iBus MDT terminal, microphone and speakers.

The cab area must be designed to accommodate the ticketing equipment as described in electrical section and in the specification document "Guidelines for Bus Builders for the installation of Ticket Machines with Smart Card Readers", published by the ticketing system supplier and available from LBSL

### 8.2 Passenger saloon ergonomics

#### 8.2.1 Windows

All side glass windows (excluding doors and driver's signal window) of identical tinted glass, where legally permitted.

- Solar energy transmittance of not more than 65%
- Light transmittance of not more than 80%

#### 8.2.1.1 Skylight Roof

[Skylight Roof – specification to be provided in next BVS update]

*The 'Skylight Roof' specification is currently under development by TfL. At this time system suppliers and OEMs are encouraged to engage with TfL for installation requirements and implementation dates.*

# London Buses

New Bus Specification Version 2.5

## 8.2.2 On Board Next Stop Signs (OBNSS) and Information Displays

As part of the iBus system, illuminated display signs providing passengers with information on the next stop will be provided (on both decks where applicable).

These shall:

- PSVAR2023 came into force on 1<sup>st</sup> October 2023, regulating quantity, quality and accessibility of On-Board information systems.
  - All new vehicle deliveries from June 2024 shall comply with this requirement.
  - **NOTE: In order to maintain consistent quality and accessibility standards across the fleet, all proposed information screen design and location drawings must be presented as part of/within GA Drawings to LBSL for approval prior to fitment and implementation**
- Be suitably positioned for maximum visibility to passengers.
- Provide suitable mouldings and fixings for the LBSL provided iBus signs.

Duplication of this iBus signage is not permitted unless with LBSL's prior written consent.

***Operators should incorporate costs for the initial purchase, data and maintenance costs when submitting tenders.***

***[More detailed hardware, content and design specification will be provided in next BVS update]***

## 8.2.3 Interior Saloon Lighting

Interior saloon lighting shall provide the minimum levels of illumination at the locations defined below:

- Seats, 150 mm above cushion level: 150 Lux
- Aisles, at floor level on bus centreline adjacent to each and every seat: 100 lux
- Steps, at floor level at the centre of entrance and exit steps: 100 lux
- Double deck stairs, at floor level on the centre of every tread: 100 lux

The interior saloon lighting shall be automatically switched off when exterior ambient illumination levels are sufficiently high.

Turning on of the interior lighting shall remain under the driver's control.

## 8.3 Heating, Ventilation & Air Conditioning (HVAC)

### 8.3.1 Drivers Cab

#### 8.3.1.1 Drivers Cab HVAC

- The HVAC system for the bus shall keep the driver's cab air supply and recirculation system completely separate to the passenger saloon system.
- The HVAC system shall be capable of feeding the driver's cab (DCAB) with 100% fresh air as well as a mix of fresh air and recirculated air, and shall provide an automatic, demand controlled ventilation system that automatically keeps

# London Buses

New Bus Specification Version 2.5

CO<sub>2</sub> levels in the cab below 800ppm at all times. Evidence of this shall be provided as part of the Assessment Protocol detailed in Attachment 9.

- The CO<sub>2</sub> sensor shall be placed under the dashboard, away from vent.
- Continuous operation shall be ensured up to 45°C (ambient). Above 35°C (ambient), the system may operate with a permissible derating, but shall reduce temperatures by ≥10°C in the driver's cab.
- The driver shall be able to control:
  - Driver selectable cab target set point temperatures at every 0.5°C interval, with a range covering at least between 17°C and 22°C (interior).
  - System heating and cooling output (between -3°C and 45°C ambient temperatures).
  - Vent air blowing direction.
  - Fan speed (where driver demand is above the minimum required fresh air demand to meet the required 800ppm CO<sub>2</sub> level), must be capable of providing air speeds between a range of 0m/s to a minimum of 1m/s, with at least 5 driver selectable fan speed intervals. This shall be measured from a vertical distance of 1.1m from floor level relative to the centre of the surface of the driver's seating position.
- All air vents in the driver's cab shall deliver treated fresh air to meet the driver's demand. The driver shall always have full control over whether or not the fresh air is heated or cooled. All air vents shall deliver a homogenous mix of air.
- There shall be a minimum of two vents blowing directly towards driver's face and additional two vents towards the feet:
  - These shall be adjustable, such that the driver shall be able to control the direction of air flow from each vent.
  - Driver's cab heating and cooling shall operate continuously without auto deactivating when bus is stationary, passenger doors are opened or during any other operational situation.
  - Heating and cooling modes shall not be able to operate simultaneously.

### 8.3.1.2 *Windscreen Demist*

A windscreen demisting system shall be provided on all vehicles. This may be either, but not limited to, an electronically heated windscreen or an air supplied system. The system shall be fully controlled (temperature and fan speed for air supplied systems) by the driver, with the ability to turn the function on/off from the driver controls without affecting driver heating/cooling.

- Where an air supplied system is fitted, it shall:
  - Operate independently from the saloon heating, upper deck cooling or cab air conditioning.
  - Be fed by exterior fresh air, or with recirculated air within the driver's cab if CO<sub>2</sub> levels are below 800ppm; there shall be no mixing or recirculation with passenger saloon air.

For all systems, the windscreen shall demist effectively and equally on both sides of the driver assault screen partition and meet the performance requirements detailed in Attachment 9 - Section 9.2.3.

## 8.3.2 Passenger Saloon

### 8.3.2.1 Passenger Saloon HVAC

All buses shall be fitted with a fully automatic saloon HVAC system. These HVAC-systems shall meet the following requirements:

- They shall be blown air HVAC systems and shall be automatically controlled, delivering air from vents along the the nearside and offside, with exceptions for door apertures, to both lower and upper deck where applicable. The HVAC system shall be designed for each applicable deck such that:
  - Heating shall be supplied at floor level (at a maximum vertical height of 0.3m above floor level).
  - Cooling shall be supplied from ceiling level (at a maximum vertical height of 0.3m below the ceiling, where the ceiling is defined as the highest point of the interior of each applicable deck).
- All direct contactable vent surfaces and air flow temperatures shall not exceed 45°C.
- A maximum air velocity of 5m/s is permissible at shoulder height for a passenger. This means:
  - 1.1m for seated passengers.
  - 1.6m from the floor for standing passengers.
- During cooling mode, when the system is operating at a maximum, air speeds should reach not less than 0.5m/s.
  - These velocities are measured at the centre line of each seating location at a vertical distance of 1.1m from the floor, on the bus where there are vent openings.
- The supply of floor heating within the designated wheelchair area shall ensure that:
  - Any ducting/vent designs do not cause ANY of the following:
    - Obstructions to wheelchair access
    - Wheelchair manoeuvrability issues or difficulties
    - Prevention of the correct safe travel positioning of the wheelchair/scooter.
  - The wheelchair bay still meets the requirements detailed in Section 7.3.1 and Table 6\_1 of this document.
- Should there be any electrical resistance heaters used in the saloon, only Positive Temperature Coefficient (PTC) type shall be used wherever possible.
  - **Any use of non-PTC heater shall be requested in writing to TfL and is only to be fitted if approved in writing by TfL.**

### 8.3.2.2 Passenger Saloon HVAC Thermal Performance

The HVAC system shall be designed such that it maintains the saloon at comfortable temperature and humidity levels for passengers, based on the ambient air temperatures.

In order to ensure passenger comfort as well as energy efficiency, the HVAC system shall not continuously change from heating to cooling and vice-versa to maintain these setpoint saloon temperatures.

#### 8.3.2.2.1 Temperature Sensor Locations

A minimum of 2 temperature sensors shall be used per zone, in each of the three zones (where relevant) highlighted in Figure 8\_1 below, for effective measurement of temperatures and minimal disturbance.

The first temperature sensor shall be placed at a height measured from floor level of 0m to 0.3m, and the second sensor shall be placed at a height between 0.9m to 1.2m when measured from floor level.

The sensors are to be positioned, such that no direct blown air or convection heat is directed at the sensors.

The ambient temperature sensor should be positioned so that it is not directly influenced by wind effect or solar radiation.

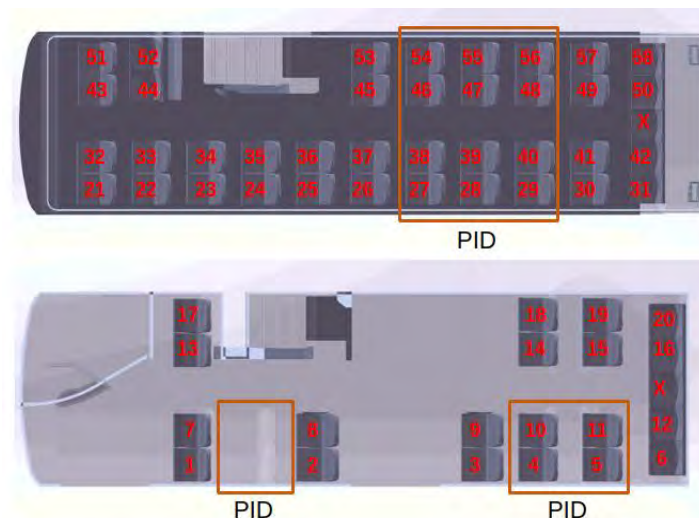

**Figure 8\_1: Approximate locations for temperature sensors on lower and upper decks where relevant to vehicle type**

# London Buses

New Bus Specification Version 2.5

## 8.3.2.2.2 Saloon Temperature

A combined 3-minute rolling average temperature shall be calculated per deck, to derive saloon temperatures as per Table 8\_1, using all temperature sensors and used for the automatic thermostatic control.

| Ambient Temperature, $T_A$ (°C) | Saloon Temperature, $T_s$ (°C) |
|---------------------------------|--------------------------------|
| -3                              | 13                             |
| 5                               | 13                             |
| 12                              | 16                             |
| 17                              | 17                             |
| 25                              | 22                             |
| 30                              | 26                             |
| 35                              | 26                             |

**Table 8\_1: Ambient vs Saloon temperature set point**

To calculate saloon temperature for any given ambient temperature between 5°C and 12°C:

$$T_s = (3/7)T_A + (76/7)$$

To calculate saloon temperature for any given ambient temperature between 12°C and 17°C:

$$T_s = (1/5)T_A + (68/5)$$

To calculate saloon temperature for any given ambient temperature between 25°C and 30°C:

$$T_s = (4/5)T_A + 2$$

## 8.3.2.2.3 Temperature Set Points

Heating and cooling modes shall not be able to operate simultaneously, thus the HVAC system will switch between operating in one of the three modes below as temperature set points demand:

- **Heating** - Between ambient temperatures of -3°C to 17°C there shall only be heating
- **Cooling** - Between ambient temperatures of 25°C to 35°C there shall only be cooling.
- **Maintaining** - Between ambient temperatures of 17°C to 25°C no heating or cooling is necessary.
  - **NOTE:** Although no heating or cooling is required during Maintaining operation, recirculation or fresh air introduction may be required to maintain the requisite temperature set point.

Continuous operation shall be ensured up to 45°C (ambient). Above 35°C (ambient), the system may operate with a permissible derating, but shall reduce temperatures by ≥5°C in the passenger saloon.

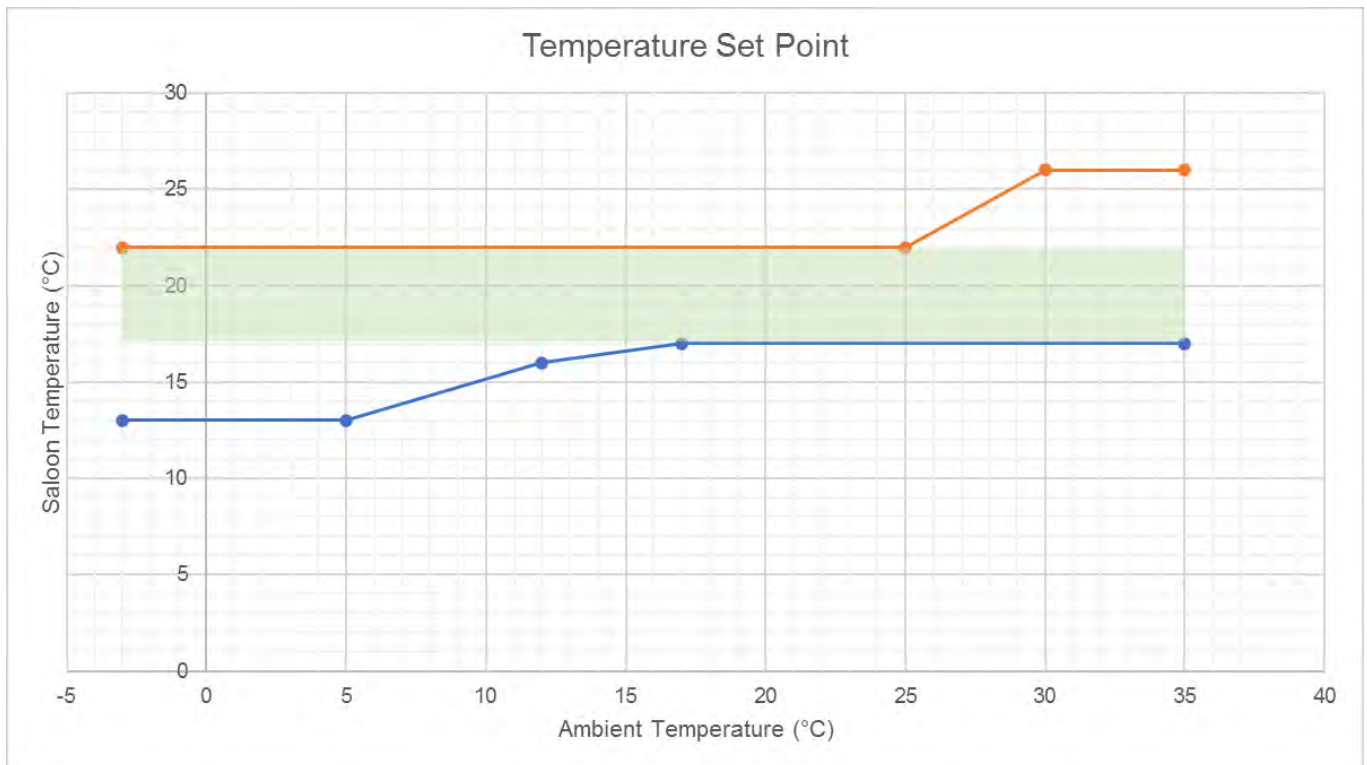

**Figure 8\_2 Temperature set points for heating and cooling lower limits**

- The shaded areas in figure 8\_2 represent the recommended upper and lower limits for heating and cooling respectively.
- Temperature differentials shall remain as low as possible with:
  - A maximum allowable deviation of 5°C across the bus, in each deck, in the longitudinal axis
  - A maximum allowable deviation of 3°C in temperatures in the transverse axis, from head level to foot level.

### 8.3.2.2.4 Saloon Humidity Control

With regards to humidity during cooling modes, the bus shall ensure that:

- a) Humidity does not exceed a maximum of 50% relative humidity when interior temperatures are between 30°C to 40°C
- b) Humidity does not exceed 70% when bus interior temperatures are between 0°C and 24°C
- c) Between 25°C and 29°C the humidity may linearly decrease within limits shown in figure 8\_3:

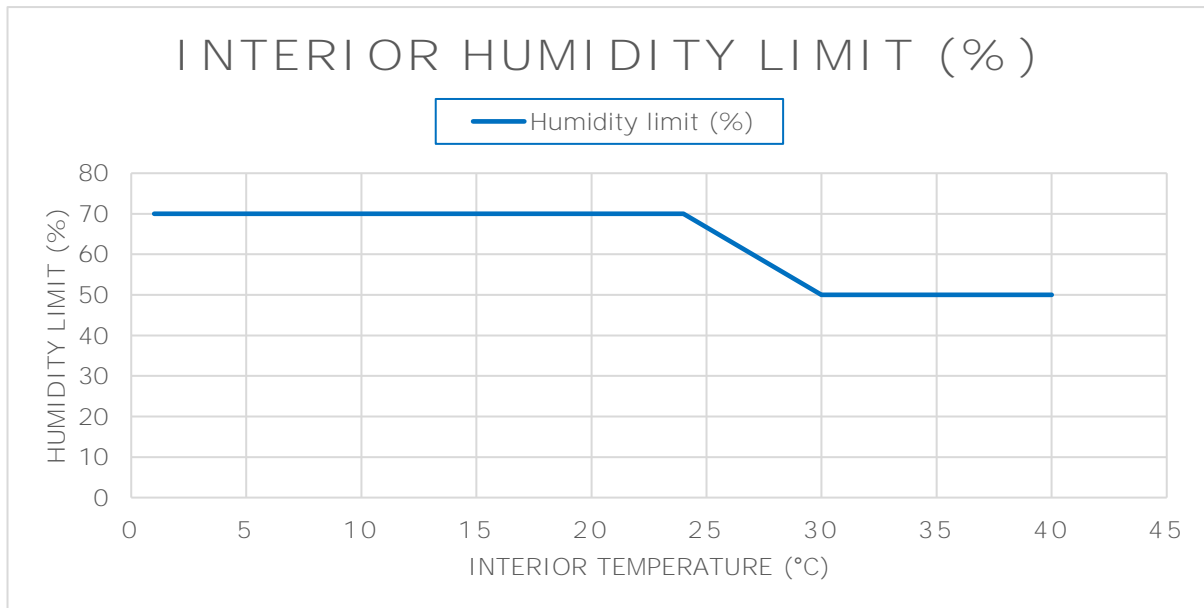

**Figure 8\_3: Air humidity as a function of the interior temperature**

### 8.3.2.3 *Passenger Saloon HVAC Ventilation Performance*

#### 8.3.2.3.5 **General Performance Requirements**

All buses shall be equipped with a demand-controlled forced ventilation system designed to automatically keep CO<sub>2</sub> levels below 1200ppm. Below 1200ppm, the HVAC system may operate in recirculation mode.

Fresh air supply shall automatically increase depending on the CO<sub>2</sub> levels in the passenger saloon up to a maximum of 15m<sup>3</sup>/h per person of fresh air for a fully loaded vehicle.

The external air inlets to the HVAC system for the saloon only shall be greater than 2m from ground level.

The ventilation system shall:

- Provide good circulation of air throughout the length of the bus interior and ensure an even temperature and fresh air distribution.
- Utilise a control system to calculate 3-minute rolling average CO<sub>2</sub> levels per deck for determination of saloon CO<sub>2</sub> levels and ventilation control using all CO<sub>2</sub> sensors.
- Be independently controlled and delivered to both lower and upper decks where applicable. The HVAC system shall be designed such that fresh air can be supplied to the lower or upper deck independently, depending on the calculated CO<sub>2</sub> averages.



### 8.3.2.3.6 CO<sub>2</sub> Sensor Locations

A total of three CO<sub>2</sub> sensor shall be fitted to the vehicle, with one positioned in each of the three zones highlighted in Figure 8\_1 in a tamper proof location. They should be located as follows:

- On the lower deck, the CO<sub>2</sub> sensors shall be placed in each of the two PID Zones at a height measured from floor level of 0m to 0.3m .
- On the upper deck, the CO<sub>2</sub> sensor shall be placed on the PID Zone at a height measured from floor level of 0m to 0.3m .

### 8.3.2.4 HVAC Air Filtration

All HVAC systems shall be fitted with air filtration on the recirculation section of the system which meets either;

- a) A minimum efficiency standard of ISO16890 Coarse 65%, minimum anti-viral efficiency of 99.9% against ISO18184 and minimum anti-bacterial efficiency of 99.9% against ISO20743

OR

- b) A minimum efficiency standard of ISO16890 ePM1 (very fine filtration capable of virus capture) whilst maintaining acceptable change interval frequencies.

OR

- c) Another method which can be independently verified to provide equal or superior performance to a) and b)

### 8.3.2.5 Window Ventilation

Provision for passenger saloon ventilation should be provided by opening (hopper vent) side windows. These opening windows shall:

- Be lockable
- Be capable of being fixed in a fully open position
- Shall not required the hopper window frame to be dropped if lower fixed glass is broken

At least 11% of the total surface side glass area (excluding door glass and destination glass) should be of the open hopper type, providing an open area air gap of not less than 3.5% of total glass area.

On single deck buses such windows shall be provided at all full-size bays.

On double deck buses ventilation windows shall not be fitted above the staircase, however, such windows shall be provided:

- Lower deck - At all full size bays
- Upper deck
  - At foremost full size bay, nearside and offside
  - At rearmost full size bay, nearside and offside
  - At one other full size bay, nearside and offside

# London Buses

New Bus Specification Version 2.5

## 8.3.3 Thermal Insulation

All side walls and roof areas shall be fully insulated. Moreover, the floor surface should also be insulated.

To reduce the coefficient of heat transmission as much as possible, suitable materials shall be used and/or suitable design measures like coated panes or insulation glass shall be taken. In addition to this, insulation materials shall comply with the requirements set out in LBSL Attachment 6: Standard for The Fire Retardant Properties of Materials.

To achieve sufficient comfort, the surface temperatures of the single surfaces in the bus shall deviate as little as possible from the average interior temperature.

## 8.3.4 General Requirements

### 8.3.4.1 HVAC Test Switch

An HVAC system test switch shall be fitted to temporarily override the automatic thermostatic controls and driver selectable cab controls. Activation shall force the drivers cab and passenger saloon HVAC system to either 100% heating or 100% cooling output, depending upon selection. All HVAC fan blowers and heating/cooling output sources shall be activated as relevant. The test mode selection shall be active for 10 minutes, after which time the system must automatically deactivate and return saloon to automatic thermostatic, and cab to driver control. The test switches shall be located within the passenger saloon, behind a panel that is easily accessible and removable without specialist tools, such as behind a panel above a saloon door. The switches shall not be located within the driver's cab.

### 8.3.4.2 Maintenance

If "maintenance only" shut off valves are required, they must utilise an independent hand tool and not be capable of being adjusted by lever or hand operation. The system should be designed to enable a full operational check of component functions and settings in the regular service routine.

Any maintenance or testing function must be automatically reset to its full operational condition after every vehicle restart or ignition cycle.

### 8.3.4.3 Vehicle Pre-Heat

A pre-heat capability to soak upper and lower deck interior areas with forced heated air to warm up the side panels, hand poles and seating surfaces may be used.

## 8.4 Seating

### 8.4.1 General Seating Requirements

Operators should provide generous seat pitches throughout the bus to permit ease of movement and local stowage of hand luggage. Particular attention to generous spacing should be given to the seats in the upper saloon on double-deck buses. General arrangement drawings and capacities shall be agreed with LBSL by the OEM as part of General Assembly drawings uploaded to the TfL BVS Database. and should not be adjusted without prior approval from LBSL.

# London Buses

New Bus Specification Version 2.5

Individual passenger seats shall be installed at all seating positions and shall be no less than 440 mm wide, including moulded panel areas, except when identified and accepted on drawings approved by TfL and uploaded to the TfL BVS Database.

Seats shall be equipped with securely fixed, replaceable seat and back pads. These seat and back pads shall be of sufficient thickness and quality to provide a good quality of comfort and support for passengers.

Any seat backs and pads that are moulded into body panels must provide equivalent levels of comfort to that provided by the main saloon seating.

## ***[High Back Seats – specification to be provided in next BVS update]***

***The ‘High Back Seats’ specification is currently under development by TfL. At this time system suppliers and OEMs are encouraged to engage with TfL for installation requirements and implementation dates.***

Please see below, Section 8.4.1.1 for details of further Seating requirements.

### **8.4.1.1 Seat Designs**

**For all seat design requirements, please refer to Section 4.5.2 and Section 7.1 of this document.**

## **8.5 USB Charging Points**

This section covers the general design of USB outlet units (“the outlets”) on London Buses, with dual ports outlet, and the associated works.

For all new buses, stable USB power supply and charging points shall be provided at all seating areas and the designated wheelchair area and shall be capable of charging typical mobile devices including but not limited to mobile phones and tablets. All outlets shall be mounted with no disturbance to a seated passenger’s knee.

### **8.5.1 General Requirements**

All outlets and associated hardware shall be designed and tested for high reliability, ease of maintenance and be tamper proof, considering the high-volume usage operational environment of London Buses.

Every seated passenger including wheelchair bay users, shall have access to at least one unique USB outlet unit, that complies with the technical requirements as specified in Table 8\_2.

All outlet units shall contain Dual USB ports integrated into a single outlet unit, they shall contain:

- 1 x Type-A output charge port
- 1 x Type-C output charge port.

The outlet units and associated hardware shall incorporate interchangeability with similar outlet modules and shall be designed to allow backward-compatibility for potential future modification, including but not limited to allowing replacement with dual Type-C port outlet units.

The outlet unit design shall incorporate ease of replacement and maintenance, such that works can be carried out without disconnection or modification of the field wiring.

# London Buses

New Bus Specification Version 2.5

The position of the outlet unit shall be placed to have good accessibility to the designated users with reduction of chances of conflicts by different passengers on board.

## 8.5.2 Technical Requirements

The OEM shall provide a USB charging system that has capability to sustainably deliver full charging services for a minimum of 60% of connected devices simultaneously without impacting the vehicle's ability to successfully complete its duty cycle.

All outlet units and accessories shall be waterproof to IP65 or better rating.

The USB charging system shall be powered on with the master switch only, switching the main battery isolator on shall not deliver power to any USB outlet units.

All USB outlet units shall fully comply with the minimum requirements specified in the technical specification below in Table 8\_2:

|                                     | <b>Dual USB outlet</b>  |
|-------------------------------------|---|
| <b>Mounting Method</b>              | Rear fit  |
| <b>Input Voltage</b>                | 9-32 V  |
| <b>Output Voltage</b>               | 5.2 V DC $\pm$ 0.2 V  |
| <b>Power Conversion Efficiency</b>  | $\geq$ 85 %   |
| <b>Minimum Maximum Power Output</b> | Dual A&C: 3.6 A   |
| <b>USB Connector</b>                | 2 x USB Ports: <ul style="list-style-type: none"> <li>• 1 x USB (Type-A; USB 3.0 or higher)</li> <li>• 1 x USB (Type-C; USB 3.0 or higher) complying to IEC 62680:2022</li> </ul> |
| <b>Output Indicator</b>             | 1 x Blue light emitting diode (LED) to provide visual display of the on/off status  |
| <b>Accessories</b>                  | No dust cover shall be fitted   |
| <b>Chassis Type</b>                 | IP65 Rated or better  |
| <b>Environmental ratings</b>        | Operation temperature: 0°C to +55°C or better;<br>Relative humidity: 20% - 90% or better, non-condensing  |
| <b>Certification</b>                | IEC 62680:2022 for Type-C port<br>EN 50498 for Electromagnetic compatibility (EMC)<br>ISO 7637-2 for road vehicles transient voltage protection                                   |

**Table 8\_2: USB Port Technical Specification**

# London Buses

New Bus Specification Version 2.5

## 8.5.3 Electrical Protection

The USB charging system shall be fully protected against overloads and short circuits, and will automatically shut down an individual outlet unit if faulty equipment is plugged into it.

All outlet units shall be properly fused. Individual fuses are required for each USB outlet unit, a normal dual Type A and Type C USB outlet unit that has a maximum rated power output of 3.6 A shall use a 5 A fuse.

At least one main fuse shall be installed per side, per deck in addition to individual outlet unit fuses.

Electrical wiring diagrams shall be provided to the bus operator for all works for maintenance purpose.

## 8.5.4 Installation of Outlet Units

Units shall be fixed between the height of 800 mm to 1000 mm measuring from floor level.

The outlets shall be manufactured and installed with a high level of robustness, employ materials with high durability and resilience.

All ports' opening shall be pointing no more than 20 degrees upwards measured vertically.

The maximum allowable protrusion relative to the surrounding installation surface, inclusive of outlet unit ring and housing, shall be  $\leq 12\text{mm}$ . No protruding base mounting pod shall be used. All requisite wiring and components shall be protected from passenger tampering or misuse by preventing any visible access potential to passengers.

Where any pair of seats is: -

- Facing the back of another pair of seats,
  - A single outlet unit shall be mounted and fixed on the back of the front pair of seats, located on the window side of the aisle seat.
  - Maintain a minimum distance of at least 40 mm from all edges of the seat.
  - Installation location shall be consistent throughout the bus.
- Facing the front of another pair of seats (bay seat arrangement),
  - Two outlet units shall be fixed on the window side wall or vertical window pillar.
  - All cables shall be run behind interior panels or covers.
  - In case of any outlet to be installed near any handrails or stop bells, a minimum of 40 mm clearance is required, as in Figure 8\_4 below.
  - Installation location shall be consistent throughout the bus.

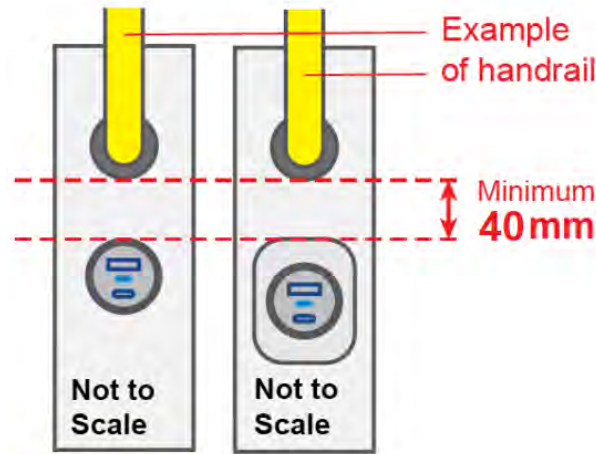
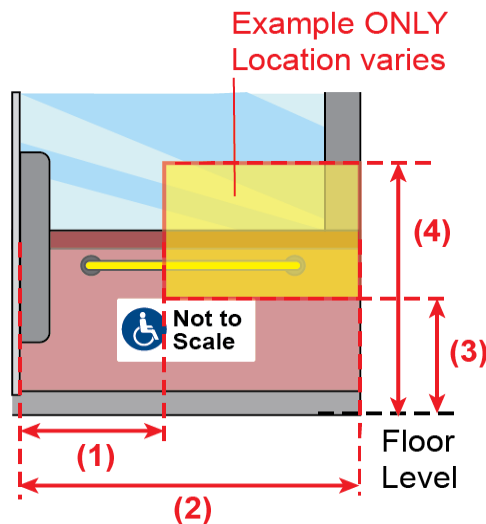

**Figure 8\_4: Illustration of clearance (not to scale, for reference only)**

- Facing a bulkhead or any panel,
  - A single outlet unit shall be fixed on the bulkhead or panel, positioned horizontally middle between two seats.
  - Avoid any attachment to removable panels.
  - Utilise only hardware and materials that guarantee a secure fitting,
  - Shall not be affixed to any glass surfaces or main body structural columns.
  - In the area near the door aperture, the outlet unit shall be positioned to be used only by seated passengers and to discourage standees near the door aperture from using the ports.
- Rearmost 5-seater centre seat when applicable,
  - No USB port is required for this position.
- Side facing seat including tip-up type,
  - A single outlet unit shall be fixed in the middle between the pair of seats, located along the top edge of the seats.
  - Installation location shall be consistent throughout the bus.
- Tip-up seat integrated with wheelchair backrest or Perch seat,
  - No separate USB outlet unit is required

For wheelchair bay area as shown in Figure 8\_5, the whole unit of outlets shall be mounted inside the range of (3) 700 mm to (4) 1000 mm height from finished floor level; and (1) 800 mm to (2) 1200 mm horizontally away from the back of wheelchair back rest. The outlet unit shall be fitted without interference with the normal use of the horizontal hand pole and shall be explicitly positioned for the use of the wheelchair user.

No pole-mounted outlet units are allowed in anywhere of the vehicle.



**Figure 8\_5: Example of allowable installation areas within the wheelchair bay, (not to scale, for reference only)**

### 8.5.5 Visual Requirements

All installations, components, and accessories shall integrate visually and stylistically with the overall interior design of the vehicle. Please consult the relevant design standard documents for comprehensive guidance.

This means, but shall not be limited to:

- Outlet units shall have no exposed wires.
- All outlet unit edges and corners shall possess a radius equal to or greater than that of the adjoining object and shall not cause an increase in scoring when assessed as part of Attachment 34 – Occupant Friendly Interiors
- Consistent adherence to the colour code of the adjoining object or interior livery.
- Outlet units shall make use of materials and finishes identical to those of the surface to which they are attached.
- No conduit mounted on interior panels which are visible to or accessible by passengers.

Should there be any conflict between these visual requirements and practical requirements during installation, these shall be raised with LBSL for review and further guidance on a case-by-case basis.

## 9 Aesthetics & Image

Closed circuit television (CCTV) security cameras, monitors, digital recording devices, safety enhancements, iBus and ticketing systems are considered an integral part of the bus design and the necessary visual attention to their design and installation detail must be taken. Wiring looms should be integrated by the OEM's where possible.

### 9.1 Flooring Appearance

*Alternative customer-friendly flooring designs and colour schemes (e.g. wood-effect flooring) should be considered for installation. In order to maintain consistent quality and accessibility standards across the fleet, all proposed designs must be presented as part of/within GA Drawings to LBSL for approval prior to fitment and implementation.*

Further information about flooring requirements are detailed in Section 4.5.6 Flooring and Slip Prevention, of this document.

## 10 Route and destination board, signs and notices, livery, advertising etc

### 10.1 Destination and Route Number displays

Buses shall be equipped with power operated front, side and rear destination displays simultaneously controlled by one route / destination selection unit in the driver's cab. It is essential that all displays are correctly positioned and coordinated whilst a bus is in service, regardless of the equipment type used, and this is the Operator's responsibility. It shall be possible for the driver to easily identify from the cab seat that the front display is correctly positioned. Dimensions for all display units shall comply with the requirements of Attachment 10.

All destination displays shall use Transport for London's New Johnston condensed font in white on a black background including out of service or any other passenger information.

All destination displays shall be fully back illuminated by LED type lighting systems and automatically illuminated at all times. Light sources shall be positioned at the horizontal centreline of each blind, providing an even distribution of illumination across the full blind area.

No light illumination gaps shall be visible around any point on the displays from the exterior view of the bus.

No logos, signs or abbreviations are permitted on the destination display. The approved ultimate and intermediate display wording will be provided by LBSL by the formal Route Record.

Where double letters or numbers occur on any display, additional separation space shall be provided to improve identification.



# London Buses

New Bus Specification Version 2.5

Blind jockey rollers or other devices must be utilised when necessary to keep blinds taught and as close as possible to the glazing line

All displays shall be equipped with an exterior anti-vandal impact and anti reflection overlay.

The front route display shall show the ultimate destination with a single track number in a side by side arrangement.

- The front visual display shall be no smaller than that defined in Attachment 10.
- The ultimate destination shall be displayed at the maximum height/size available. A proportional reduction in font size is permitted only where necessary to accommodate long destination points.
- The ultimate destination sight size (visible area) shall not be less than 1160mm in width and 330mm in height.
- The route number shall utilise the full depth available from the display height and shall have a sight size of not less than 450mm in width and 330mm in height.
- The destination shall display the wording defined in the Route Record issued by LBSL only, no intermediates, logos, qualifiers, curtailment points or any other information that is not part of the approved wording shall be shown

The nearside route display must have the ultimate destinations and single track number in a side by side arrangement. The route number must be shown to the forward most point of display.

- Equipment may be a combined single track or split number but in either case must achieve the dimensions defined in Attachment 10
- The ultimate destination and route number shall utilise the full first window bay width
- The side visual display shall be no smaller than that defined in Attachment 10
- The ultimate destination sight size shall not be less than 687mm in width and 210mm in height
- The route number shall utilise the full depth available from display height and the sight size shall not be less than 270mm in width and 210mm in height.
- The height of the horizontal centreline of the characters in the display shall not be less than 1200mm or more than 2500mm from ground at the normal bus ride height.

The Rear route display shall display a number identical to the independent front route number display.

## 10.1.1 Digital Bus Blinds

[Digital Bus Blinds – specification to be provided in next BVS update]

***The 'Digital Bus Blinds' specification is currently under development by TfL. At this time system suppliers and OEMs are required to engage with TfL for installation requirements and implementation dates.***

## 10.2 Running Numbers

Running number boards (if utilised) must be positioned and displayed in a manner that cannot be misinterpreted as a route number. They should be to the sides of the vehicles on the bodywork, or if in the windscreen area in a position that does not in any way obstruct the drivers' view.

- The character font must be yellow on black
- Font size shall not be greater than 200mm in height
- The display shall be of a professional appearance.
- Soft print copy taped or positioned adjacent to windows is not permitted

## 10.3 Other Internal and External Signs and Notices

Exterior and interior notices are provided by LBSL as listed in the London Buses – Bus Graphics Standard (<https://content.tfl.gov.uk/london-buses-bus-graphics-standard-issue05.pdf>), and must be fitted in the appropriate positions.

All such notices shall be as defined in the booklet Manufacturers' Application Procedure. These notices may be obtained by bus OEM or operators FOC from the current supplier Stewart Signs.

Specific operator notices shall not be permitted, for example

- Operator specific Welcome Aboard notices (on driver's cab door, panels, glass, or in floor covering )
- No notices, information, legal address, recruitment or any other advertising material is permitted on the interior or exterior of any window without prior permission of LBSL
- CCTV advisory notices
- Audio advisory notices

Notices provided by operator must be fitted in the appropriate positions:-

- Fleet numbers and operator identification code shall be marked on the roof. Operator codes shall be as defined in Attachment 13 with black cut out lettering of operator code over fleet number, character New Johnston Bold font 350mm in height, positioned on centre line of bus, transversely at rear of white roof section.
- Operator logo positions shall be as agreed in management document illustrations for each operator
- All external and internal legal notices, shall be in a single contrasting colour, cut out type if appropriate.
- All notices and signs to be in Transport for London's "New Johnston" bold or medium font unless legally required otherwise

**10.3.1 First Responders Vehicle Propulsion Identification Symbols**

Recommendations have been made by the fire service to ensure that the type of propulsion of each bus is clearly stated. Identification of propulsion systems will help to maximise the safety of staff, customers, and first responders during an incident.

- All Propulsion Identification Symbols must comply to ISO 17840-4:2018
- Drivers' daily checks shall include the visual inspection of the easily accessible Propulsion Identification Symbols (not roof), ensuring they are not damaged or missing. Any issues must be reported, in line with operator processes for issue reporting. A lower frequency check for the roof symbol should be undertaken by an appropriate person when the vehicle is off the road.
- If the propulsion system of the bus is changed, modified, or updated, it is the responsibility of the Bus Operator to ensure the identification symbols, Rescue Guide and ERG are updated accordingly.
- No Propulsion Identification Symbols shall be obscured by any livery changes. Any livery change must ensure the symbol is still visible and obvious. As shown in Figure 10\_1: if an electric bus is painted orange, the symbol shall have a black background behind it.



**Figure 10\_1 Examples of acceptable Propulsion Identification Symbol background configurations**

All Propulsion Identification Symbols shall be placed and orientated in such a way that the propulsion type can be recognised from all 5 sides of the bus.

Examples are shown in Figures 10\_2, 10\_3, 10\_4 and 10\_5.

- Nearside - Located above the front door (if not immediately above the front door, then close to it) as shown in Figure 10\_2
- Offside - Located above the driver's cab window (if not immediately above the driver's cab window, then close to it) as shown in Figure 10\_3
- Front - Located above the front windscreen on the driver's side as shown in Figure 10\_4 (left)
- Rear - Located above the rear window on the non-driver side (if appropriate, this may go on the window blacking that is either side of the rear window) as shown in Figure 10\_4 (right)
- Roof – Located at the rear of the bus, within a centralised location below the bus roof identification number as shown in Figure 10\_5



**Figure 10\_2 Nearside Propulsion Identification Symbol location**



**Figure 10\_3 Offside Propulsion Identification Symbol location**



**Figure 10\_4 Front (left) and Rear (right) Propulsion Identification Symbol location**



**Figure 10\_5 Roof Propulsion Identification Symbol location**

- All dimensions of symbols shall be per ISO 17840-4:2018. General recommendations in ISO 3864 shall be followed to ensure the symbol has the appropriate dimensions to be readable and clear from a distance. No distance is given, however a common sense approach should be taken.

## 10.3.1.1 Specific Labelling Dimensions

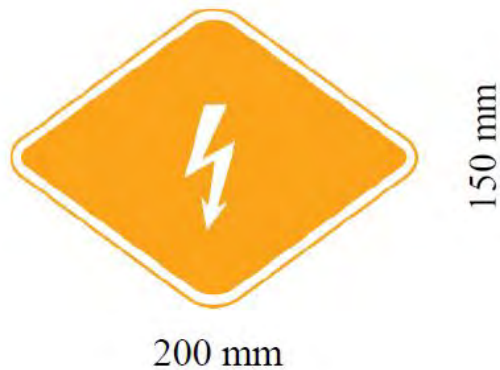

**Figure 10\_6 Front, Rear and Side Retro Reflective Propulsion Identification Symbol Dimension requirements**



**Figure 10\_7 Roof Retro Reflective Propulsion Identification Symbol Dimension requirements.**

- Colours used for type of propulsion are based on ISO 17840-4:2018 and shall also meet TfL's requirement to produce customer information in an accessible format.
- Regulations for retro reflective labels, Regulation No 104 of the Economic Commission for Europe of the United Nations (UN/ECE) — Uniform provisions concerning the approval of retro- reflective markings for vehicles of category M, N and O. Class E shall be applied.

## 10.3.1.2 Hybrid Vehicles

Only Class B voltage systems may show the hybrid label as per ISO 17840-4:2018. A class B voltage system is classified in Figure 10\_8 below.

**Class B voltage system: Orange RGB 255, 165, 0**  
 classification of an electric component or circuit with a maximum working voltage between 30 V a.c. (rms) and 1 000 V a.c. (rms) or between 60 V d.c. and 1 500 V d.c.  
 Source: ISO 6469-3:2011

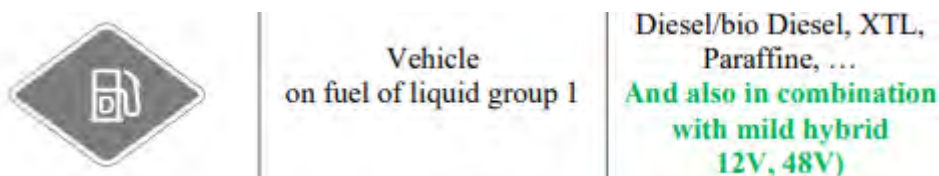

**Figure 10\_8 Class B Voltage System Classification**

A hybrid vehicle that is below 60V is classed as a mild hybrid. The orange hybrid label may not be displayed on any hybrid vehicle below 60V. This information was provided within the ISO 17840 guidance document 'Info Guideline Road Vehicles Bus or Coach'. The propulsion label shown on a mild hybrid must be for the diesel vehicle shown in Figure 10\_9



**Figure 10\_9 Propulsion Identification Symbol requirement for Mild Hybrid vehicles**

As per the ISO 17840 guidance document 'Info Guideline Road Vehicles Bus or Coach', only class B voltage may display the hybrid propulsion label as per Figure 10\_10 below

|   |  |   |
|---|--|---|
|  | Hybrid Electric Vehicle<br>on fuel of liquid group 2<br>(Gasoline, Ethanol,) | Only class B voltage<br><b>Not for mild hybrid<br/>(12V, 48V)</b> |
|  | Hybrid Electric Vehicle on<br>fuel of liquid group 1<br>(Diesel, XTL)        | Only class B voltage<br><b>Not for mild hybrid<br/>(12V, 48V)</b> |

**Figure 10\_10 Propulsion Identification Symbol requirement for Class B Voltage (Hybrid) vehicles**

## 10.4 External Advertising

Exterior advertising panels are permitted in the following areas when bus width permits:-

- Off Side
- Near Side

# London Buses

New Bus Specification Version 2.5

- Rear

All advert panels must be framed with the frame in London Bus Red, except where specific LBSL authority has been given to support a particular activity. Any non-standard, illuminated or special in any way advertising method or advertising display must be approved by LBSL prior to installation.

## 10.5 Paint, Colours and Livery

All buses shall be painted in a livery that is fully London Buses Red Reference ICI P498FPF3 or exact colour equivalent with the following exemptions

- White roof panels on both single and double decks to interior cove joint (i.e. not visible from pavement level) for heat rejection
- Road wheels are not to be repainted and should remain in the OEM's standard finish

The TfL Roundel is mandatory and should be fitted in accordance with guidance contained in the latest LBSL Bus Graphics Standard (<https://content.tfl.gov.uk/london-buses-bus-graphics-standard-issue05.pdf>)

Should the livery illustration(s) incorporated into your Framework Agreement not include a livery as described above, you should enclose a copy of the rear, front and side illustrations in colour of such a livery. This will be subject to prior approval by LBSL

## 11 Design for Ease of Maintenance

Closed circuit television (CCTV) security cameras, monitors, digital recording devices, iBus and ticketing systems are considered an integral part of the bus design and the necessary attention to their long term maintenance and repair must be taken into considering when they are installed. Wiring looms should be integrated by the OEM's where possible. It is imperative that the necessary practical detail of assessing these components for maintenance purposes is taken into account.

Design and selection of materials utilised must facilitate ease of cleaning and be maintained to a satisfactory level of appearance throughout the in service bus contract period.